

PN: 915B150135

主要特性 Key Features:

- 多单管耦合, 高可靠性 Multiple single emitter based diode laser, high reliability
- 防反射保护 1040-1200nm feedback protection

应用领域 Applications:

- 光纤激光器泵浦 Fiber laser pumping
- 直接应用 Direct applications

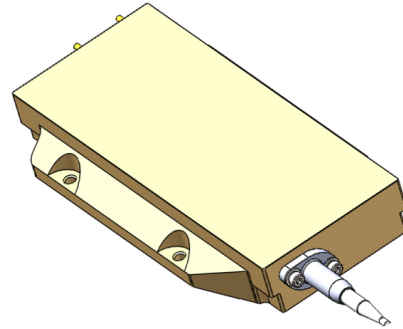

光学参数 ¹ /Optical Parameters ¹	Unit	Minimum	Typical	Maximum
输出功率/Output Power	W		150	
中心波长 ² /Center Wavelength ²	nm	900	915	930
95%出光 NA/95% Power Within NA	NA		0.18	
防反射波段/Back Reflection Isolation Range	nm	1040	1064	1200
防反射隔离度/Back Reflection Isolation	dB	30		
光纤参数/Fiber Parameters				
纤芯直径/Fiber Core Diameter	μm	133.5	135.0	136.5
包层直径/Fiber Clad Diameter	μm	154	155	156
光纤数值孔径/Numerical Aperture	NA	0.215	0.220	0.225
光纤长度 ² /Fiber Length ²	m	1.5	2.0	
套管直径/Loose Tubing Diameter	mm	1.1	1.4	
套管长度/Loose Tubing length	m	1.2	1.5	
光纤接头/Fiber Connector			Bare Fiber/SC Ceramic Ferrule	
弯曲半径/Fiber Bend Radius	mm	35		
电学性能 ³ /Electrical Parameters ³				
光电转换效率/Conversion Efficiency	%		50	
阈值电流/Threshold Current	A		1.1	
工作电流 ³ /Operating Current ³	A			29.0
工作电压 ³ /Operating Voltage ³	V			14.0
热学性能 ³ /Thermal Parameters ³				
工作温度 ⁴ /Operating Temperature Range ⁴	°C	5		45
存储温度/Storage Temperature Range	°C	-30		85
温漂系数/Wavelength Temperature Coefficient	nm/°C		0.35	
加电脚焊接温度/Lead Soldering Temperature	°C		260	300
加电脚焊接时间/Lead Soldering Time	s			10

¹ 在 25 摄氏度冷却板温度下测得。Tested at 25°C cold plate temperature.

² 可根据客户需求定制。Others available upon request.

³ 超规格使用会导致激光器寿命减少。Reduced lifetime if used above nominal operating conditions.

⁴ 激光波长会随壳体工作温度变化产生漂移。Laser Wavelength would shift when package operating temperature is changed.

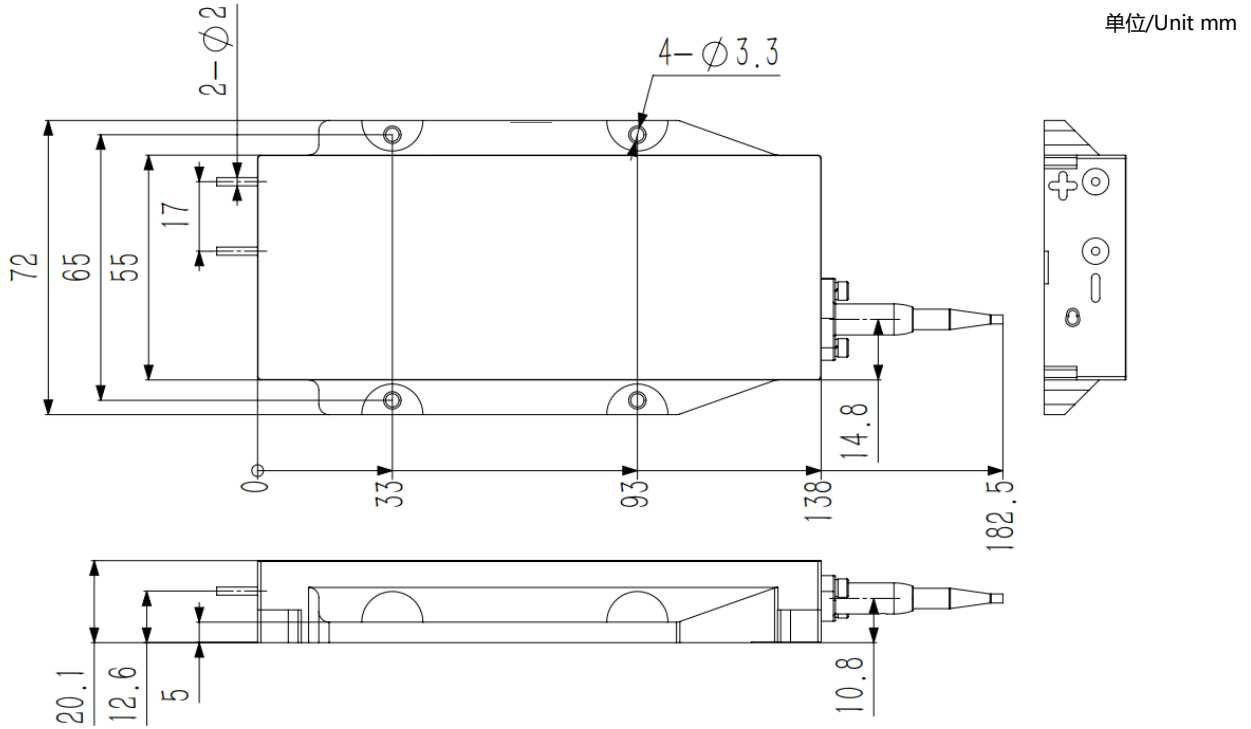

单位/Unit mm

重量典型值/Typical value of weight 927g

使用说明 Application Notes:

- 激光器输出激光是不可见光，使用时请遵守 IEC 四级激光标准安全规范，避免激光直接或间接照射眼睛和皮肤。The laser beam emitted from the diode laser is invisible, please follow the standard safety procedures for IEC Class 4 lasers, avoid eye or skin exposure to direct or scattered radiation.
- 静电击穿是导致半导体激光器失效的重要原因，激光器安装需由经过培训的人员完成，操作时需佩戴防静电手腕带，工作台需接地。在供电接头与激光器管脚连接之前，不得移除激光器管脚上的防静电保护线。ESD is the primary cause of unexpected diode laser failure. The diode laser should be handled by trained operators wearing ESD grounding straps and the work surface should be grounded. Connectors should be attached to the pump pins prior to removing the ESD shortcut protection component.
- 在激光器出光之前，请确保光纤端面清洁。Ensure the end of the fiber be free of dust and contamination before operation.
- 请参照规格书，在额定电流、电压下使用激光器。The laser should be operated according to the specifications, maximum optical power should not be exceeded.
- 电流过冲有可能导致激光器损坏，请使用稳定的驱动电源，避免浪涌。The laser may be damaged by excessive drive current, stable power supply should be used to avoid surge current.
- 为保证激光器能长期可靠运行，冷却板温度需控制在 20 - 30°C，使激光器工作在合理温度范围内。To ensure long-term reliability of the laser, a 20 - 30°C cold plate is needed to make the laser work within proper temperature range.

版本变更说明 Update Notes:

- Rev A1: Preliminary

深圳市星汉激光科技股份有限公司 Shenzhen Xinghan Laser Technology Co. Ltd

地址：深圳市宝安区福海街道新和社区蚝业路 39 号旭竟昌工业园 B4 栋五楼

5th Floor, Bldg B4, Xujingchang Industrial Park, No. 39 Haoye Rd, Bao' an District,

Shenzhen

邮箱 Email: sales@xinghanlaser.com

