

*This product is sold
and supported
in the USA by*



LASER LAB SOURCE
marketplace for **Scientists & Engineers**

contact@LaserLabSource.com

800.887.5065

915nm 158W High Power Fiber Coupled Diode Laser

K915FG2RN-158.0W



Features:

- ◆ 915nm wavelength
- ◆ 158W output power
- ◆ 105 μ m fiber core diameter
- ◆ 0.22 N.A.
- ◆ 1040-1200nm feedback protection

Applications:

- ◆ Fiber laser pumping
- ◆ Material processing

BWT Beijing's High Power Diode Laser Modules are manufactured by adopting specialized fiber-coupling techniques, resulting in volume products with a high efficiency, stability and superior beam quality. The products are achieved by transforming the asymmetric radiation from the laser diode chip into an output fiber with small core diameter by using special micro optics. Inspecting and burn-in procedures in every aspect come to a result to guarantee each product with the reliability, stability and long lifetime.

Our research staffs are constantly improving and innovating the processing technology in the producing process, based on the professional knowledge and experience accumulated in long-terms. We are also continuously developing new products to meet customers' specific needs.

At BWT Beijing, to provide high quality products with reasonable price is our always goal.

915nm 158W High Power Fiber Coupled Diode Laser

K915FG2RN-158.0W

Specifications(25°C)		Symbol	Unit	K915FG2RN-158.0W		
				Minimum	Typical	Maximum
Parameter⁽¹⁾	CW Output Power	P_O	W	158	-	-
	Threshold current	I_{th}	A	-	0.5	-
	Operating current	I_{op}	A	-	-	11
	Operating voltage	V_{op}	V	-	-	31.5
	Reverse Voltage	V_{re}	V	-	45	-
	Slope Efficiency	η	W/A	-	15	-
	Electrical-to-Optical Efficiency	PE	%	-	48	-
	Center wavelength	λ_c	nm	905	-	925
	Spectral width(FWHM)	$\Delta\lambda$	nm	-	6	-
	Back reflection wavelength Range	λ	nm	1040	-	1200
	Back reflection isolation	-	dB	-	30	-
	Wavelength Shift with Temperature	-	nm/°C	-	0.3	-
	Light within 0.22NA	-	NA	-	95	-
	Life Time	MTTF	H	-	10000	-
Fiber Date	Buffer diameter	D_{buf}	μm	-	250	-
	Cladding diameter	D_{clad}	μm	-	125	-
	Core diameter	D_{core}	μm	-	105	-
	Numeric aperture	NA	NA	-	0.22	-
	Fiber length ⁽²⁾	l_c	m	0.9	1	1.1
	Fiber Bend Radius	-	-	-	35	-
Others	ESD	-	V	-	-	500
	Storage temperature	-	°C	-20	-	70
	Lead Soldering Temp	T_{is}	°C	-	-	260
	Lead Soldering Time	T_{is}	sec	-	-	10
	Operating case temperature	T_{op}	°C	15	-	35
	Relative Humidity	-	%	15	-	75

(1) Data measured under operation output at 158W.

(2) Other fibers available upon request.

915nm 158W High Power Fiber Coupled Diode Laser
K915FG2RN-158.0W

Characteristics

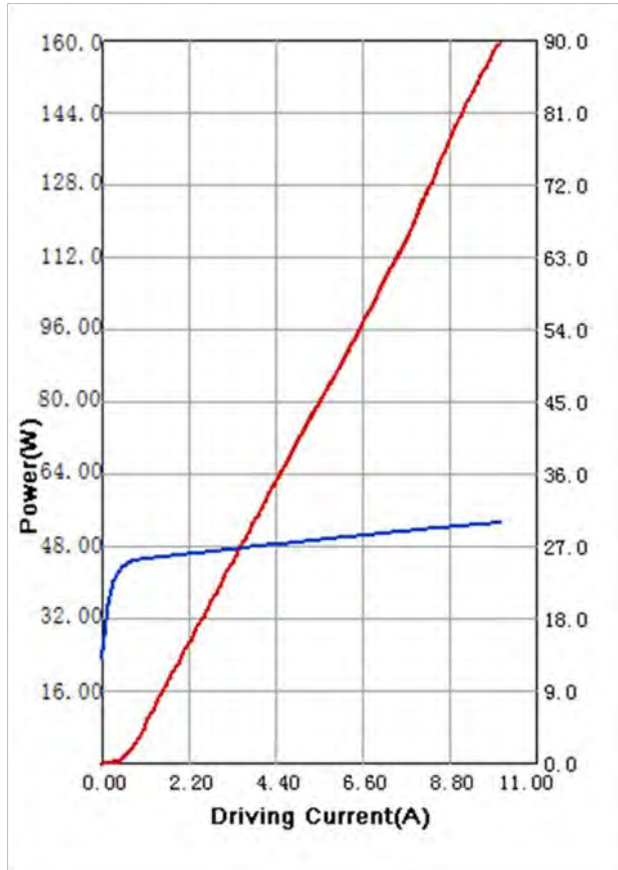

Typ. spectrum

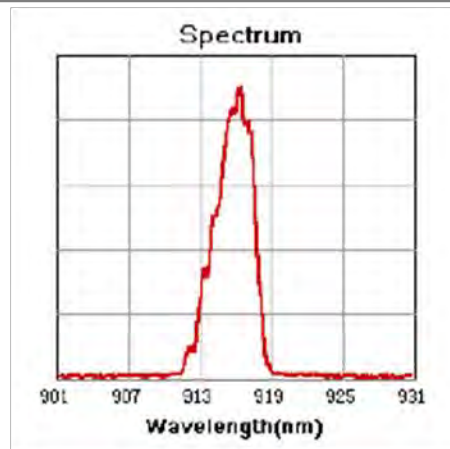

915nm 158W High Power Fiber Coupled Diode Laser K915FG2RN-158.0W

Package Dimensions (mm)

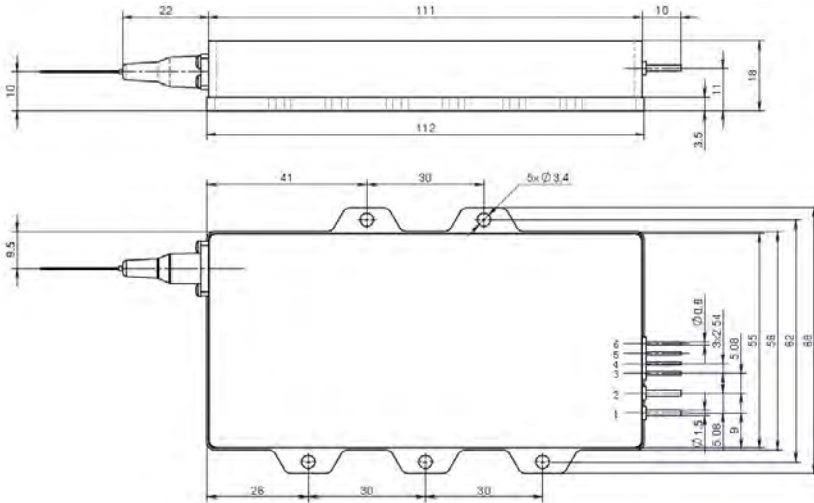

Pins	Function
1	LD (+)
2	LD (-)
3	Thermistor*
4	Thermistor*
5	PD (N) *
6	PD (P) *

*: Optional functions.

OPERATING NOTES

- ◆ Avoid eye exposure to direct or scattered radiation.
- ◆ ESD precautions must be taken.
- ◆ Please connect pins to wires by solder instead of using socket when operation current is higher than 6A.
- ◆ Soldering point should be close to the root of the pins. Soldering temperature should be lower than 260°C and time shorter than 10 second.
- ◆ Use constant current power supply. Avoid surge current.
- ◆ Laser diode must be used according to the specifications.
- ◆ Laser diode must work with good cooling.
- ◆ Operation temperature is 15°C~ 35°C.
- ◆ Storage: -20°C~ +70°C, all pins short-circuit.



Declaration: information and specifications contained herein are deemed to be reliable and accurate. BWT Beijing reserves the right to change, alter or modify the design and specifications of these products at any time without notice.