

LM Series Compact Single Frequency Laser Modules



Single Frequency

Features:

- Single frequency, collimated TEM output with long coherence length (~1m)
- Remote computer and onboard user controls with integral LCD Display
- Precision temperature and current stabilization
- Ultra-compact footprint 40mm x 42.5mm x 100mm
- Plug and play operation
- NoiseBlock™ narrow-band ASE suppression filters and beamsplitters available in matching wavelengths to further reduce linewidth and ASE noise

Applications:

- Raman Spectroscopy
- Interferometry
- Metrology
- HeNe replacement
- Bio-instrumentation
- Particle Counting
- LIDAR
- Graphic Arts
- Sensing
- Analytical Instrumentation

Ondax's LM Series Compact Single Frequency Laser Module incorporates the Ondax SureLock™ VHG-stabilized laser diode to deliver steady, single frequency performance in an ultra-compact footprint. Offering both computer and integrated user controls, the LM Series includes precision temperature and current controls to deliver better than 1m coherence length and 1% power stability with less than 1 minute warm-up. This tightly integrated package makes it the ideal choice for both OEM instrumentation and laboratory applications.

The LM Module is available in wavelengths from 405nm to 830nm.

Specifications:

Parameter	Sym-	Wavelength										
		405/406	633	638	658	685	690	780.25	785	808	830	
Center Wavelength (vacuum) ¹	L_p /nm	405/406	633	638	658	685	690	780.25	785	808	830	
Center Wavelength Tolerances	nm	±1	±0.5	±1	±1	±1	±1	±0.2	±1	±1	±1	
Output Power	P_o /mW	12/25/40	40/70	30	30	40	40	75	75/100	150	150	
Beam Size	mm	0.6 x 0.3	0.6 x 0.9	0.6 x 0.8	0.7 x 1.1	0.9 x 1.4	0.9 x 1.5	0.8 x 1.5	0.9 x 1.7	0.9 x 1.7	0.9 x 1.4	
Linewidth, maximum (MHz)	$\Delta\lambda$	160 ²	150	300	300	50	100	50	50	50	250	

¹Available in increments of 2nm. Please specify wavelength at time of ordering. ²For 405nm diode only

Operating Specifications

Optical	Min	Typ	Max	Unit
Spatial Mode	Single Mode			
Polarization	100:1			
Beam Divergence	1		10	mrad
Pointing Stability			± 25	μrad
Noise (RMS, 0-20 MHz)	0.25		0.5	%
Power Stability (1 hr)	0.10		0.5	%
Electrical	Min	Typ	Max	Unit
Operating Current			1.5	A
Operating Voltage	3.3			VDC
Modulation Input (TTL)	0			VDC
Modulation Speed			3	kHz
Environmental	Min	Typ	Max	Unit
Storage Temperature	-10			°C
Operating Temperature	10	25	40	°C
Operation Humidity	Non-condensing			
Dimensions (D x L)	100 x 80			mm

LM Series Compact Single Frequency Laser Modules

Wavelength Stability (405nm example)

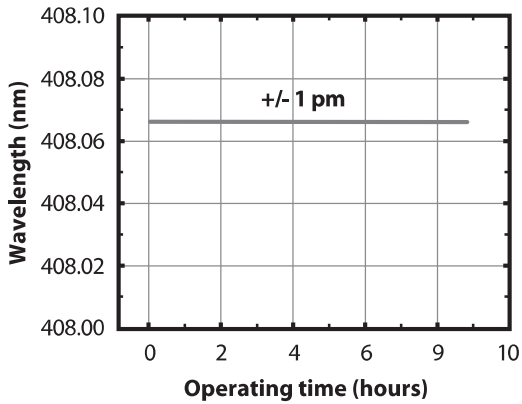

Optical Power Stability (405nm example)

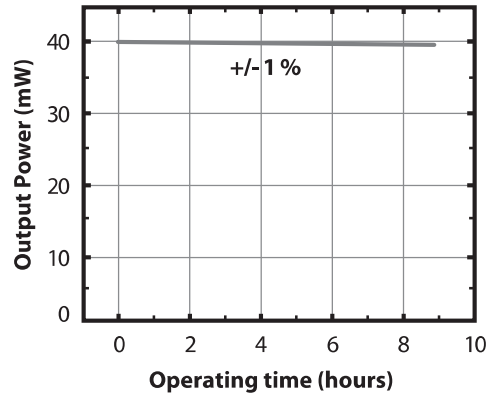

Optical Spectrum (405nm example)

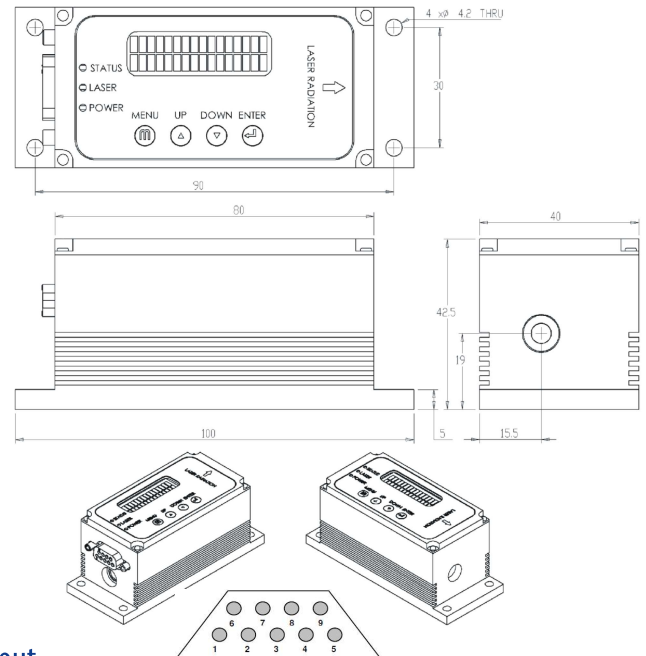
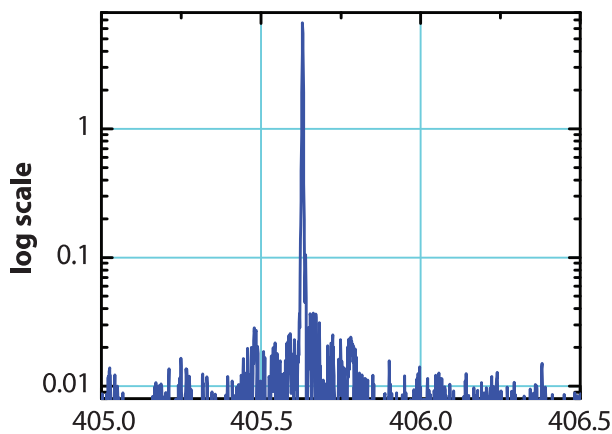

Model Numbers

LM-λλλ-PLR-Power or LM-λλλ-PLR-Power-1K (includes keyswitch)

Power Requirements

100-240V AC, 50-60Hz, Connector: +3.3VDC, 2.1mm dia.

Pinout

Pin	Definition	Description
1	VCC	Positive Power Pin +3.3V
2	TXD	Send data to computer (RS232)
3	RXD	Receive data from computer (RS232)
4		Not used
5	GND	GND for power and RS232 communication
6	TTL	Outside TTL modulation
7		Not used
8		Not used
9	GND	GND for power and RS232 communication

Note: Pinout is compatible with standard RS232 cable for interfacing with computer port or USB-RS232 adapter

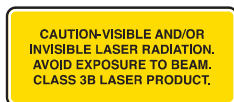

850 E. Duarte Rd. Monrovia, CA 91016
626-357-9600 (Tel)
626-513-7494 (Sales Fax)

For more information about Ondax products and the name of a local representative or distributor, visit www.ondax.com, email sales@ondax.com, or call (626) 357-9600. Specifications subject to change without notice. Each purchased laser is provided with test data and manual. Please refer to this data before using the laser.