

LuOcean P2

LU1064C Diode Laser
Up to 230 W c.w. Operating Power @ 1064 nm



Description:

The LuOcean™ P2 Diode Laser series offers OEM integrators an excellent product to manufacture state-of-the-art end user laser systems. The easy integration and safe use of these laser components give the chance to be cost-efficient in development and manufacturing. Equipped with several accessories and features the Lumics diode lasers comply with CE & ROHS requirements. Lumics warranties highest reliability single emitter technology through careful design, extensive burn-in, long life-time & thermal testing.

Features & Functions:

- Wavelength 1064 nm
- Burn-in tested single emitters
- Fiber: 200/400 or 600 μm NA 0.22
- SMA905
- Sealed housing
- Temperature sensor

Options:

- Power monitor
- Fiber sensor
- Red or green pilot laser
- Water cooling plate

Benefits:

- Ultra long lifetime
- Cost effective
- High efficiency

Applications:

- Pumping
- Illumination
- Medical treatment

Module Drawing (Dimensions in mm)

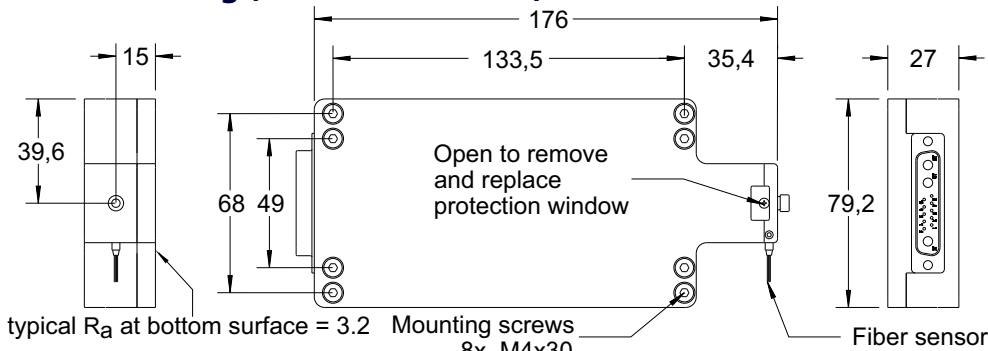

Fiber Connector

- (1) Lumics laser diode fiber coupling technology ensures loss into the fiber cladding of <2% of the total power if the fiber centricity is below 10μm and ferrule diameter and distance of the fiber end facet to the reference plane complies with shown technical drawing. Use a fiber microscope to check for dust free fiber end facet and fiber centricity.
- (2) Free standing fibers suffer from higher risk of fiber damage to the fiber tip due to mechanical stress by handling and the fiber end facet can not be polished as simple as for not free standing fibers.
- (3) For more information see http://www.lumics.de/wp-content/uploads/lu_fiber_patchcords.pdf

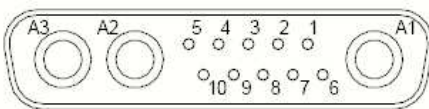
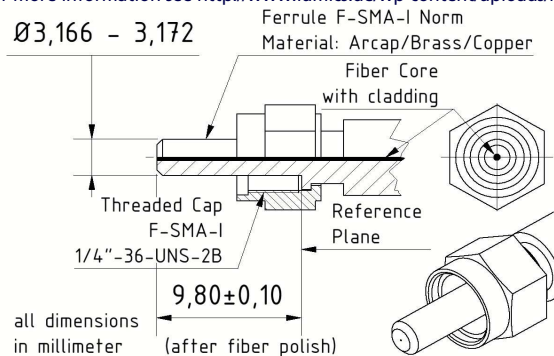

Pin	Configuration
1	2nd LM35 signal or NTC or PT100/1000 * or pilot power control (0-5)V *
2	2nd LM35 5V or NTC or PT100/1000 * or signal internal fiber sensor
3	Monitor diode cathode or internal fiber sensor 12V *
4	1st and 2nd LM35 (GND1) Monitor diode (GND1) Internal fiber sensor (GND1)
5	1st LM35 signal or NTC or PT100/1000 *
6	Monitor diode signal 2 *
7	Monitor diode signal 1 *
8	Pilot laser (GND2)
9	1st LM35 5V or NTC or PT100/1000
10	Pilot laser 8 V (green) or 5 V (red) *
A1	Laser diode (+)
A2	Laser diode cathode (-)
A3	N.C.

* Optional

We manufacture diode lasers.

Electrical and Optical Characteristics

Typical Laser specifications at 25° C *

Parameter	Conditions	Symbol	LU1064C130	LU1064C200	LU1064C230	Unit
Maximum output power (1)	c.w.	P _{op}	130	200	230	W
Operating current (2)	c.w.	I _{op}	14.5	23	26.5	A
Peak wavelength	at lop	λ	1064 ± 10	1064 ± 10	1064 ± 10	nm
Spectral width (FWHM)	at lop	Δλ	2-9	2-9	2-9	nm
Threshold current		I _{th}	0.75	1.8	1.8	A
Operating voltage		V _f	21	22	25	V
Conversion efficiency			45	40	35	%
Wavelength tuning vs. temperature		λ / T	0.3	0.3	0.3	nm / K
Wavelength tuning vs. operating current		λ / I	1	1	1	nm / A
Weight		m	1200	1200	1200	g
Thermal resistance (bottom to temp. sensor)		R _{th}	0.04	0.04	0.04	K/W
Output fiber (SMA905)						
Core diameter of output fiber		d _{core}	200	400	600	μm
Numerical aperture		NA	0.22	0.22	0.22	
Temperature sensor (10 kOhm)	LM35, NTC (10k) or PT100/1000 (please specify)					
Power monitor		PD	5-30	5-20	5-30	mV/W
Options						
Option 1: Red pilot laser						
C.w. output power min. value (4)		P _{pilot}	1-3	1-3	1-3	mW
Peak wavelength		λ _{pilot}	635 ± 10	635 ± 10	635 ± 10	nm
Operating voltage			5	5	5	V
Option 2: Green pilot laser						
C.w. output power min. value (4)		P _{pilot}	1-2	1-2	1-2	mW
Peak wavelength		λ _{pilot}	520 ± 10	520 ± 10	520 ± 10	nm
Operating voltage			8	8	8	V
Pilot power control		P _{pilot_contr}	0-5	0-5	0-5	V
Option 3: Water cooling base plate						
Water temperature		T	<18	<18	<18	°C
Water quality	Industrial Water, no DI-water, filtered particle size <0.1mm					
Minimum water flux			1.5	2	2.4	l/min
Option 4: Fiber sensor						
Internal (resistive) fiber detection sensor signal voltage			12	12	V	
A second fiber sensor is an external inductive sensor with three wire cable (Vcc=12V, GND, Signal 12/2V when fiber is plug/not plugged)						

Notes: * taken at internal temperature sensor.

Avoid direct feedback from materials like mirrors, optics, processed material etc. back into laser module via the fiber cable by more than 10%.

(1) Power is measured ex fiber according to given fiber specifications including measures and tolerances of fiber and ferrules for uncoated fiber facets .

(2) Do not exceed maximum forward current by more than 5% above given operating current and if given by the maximum current otherwise the laser diode may be damaged.

(3) Rule of thumb: Power ex fiber decreases up to 5% (<1100nm) and up to 7% (>1400nm) every 10 °C temperature increase at internal temperature sensor. Lifetime decreases by about factor of two every 10 °C. Required flatness of customer heat sink 0.05mm over 150mm to achieve necessary contact to the heat sink.

(4) Red and green minimum pilot power is set at factory by customer request. Standard is 1 mW.

Calculation example of necessary water temperature for 10 W output power:

Thermal load = Output power * (1/conversion efficiency - 1), Water temperature = internal temperature - thermal load * Thermal resistance

Example: Output power: 100 W, Conversion efficiency: 0.4, Thermal resistance: 0.07 K/W, Internal temperature: 25 °C

Thermal load = 100 W * (1/0.4 - 1) = 150 W, Water temperature = 25 °C - 150 W * 0.07 K/W = 15 °C, (water flux must be adjusted accordingly)

Absolute Maximum Ratings / General Informations

Parameter	Symbol	Min	Max	Unit
Storage temperature	T_{max}	0	+50	°C
Operating temp.* c.w.-operation **	$T_{op.c.w.}$	+15	+35	°C
Humidity / non condensing atmosphere			90	%
Recommended thermal heatsink resistance R_{th}			0.03	K/W
Max fiber flange temperature			45	°C
Max. back reflection of intrinsic pump wavelength output power			10	%
Max. back reflection any other than λ of this diode laser			10	μ J
Compliance		CE, ROHS		
Standard Accessories				
Interface connector		13w3 Female		
Mounting screws / metric		8 x M4 x 12		
Remarks				

* taken at internal temperature sensor

** we recommend to operate the laser above dew point

Option: P2 water cooling base plate with quick release water connectors and thermal resistance of 0.03 K/W.

Please note : Avoid to remove the water cooling plate from the P2 laser module because the optics is aligned with the water cooling plate attached to the P2 module. If it is removed the housing might relax mechanically which move the fiber coupling port/nose away from the focused light spot. Never change to a water cooling with a lower specifications regarding flatness

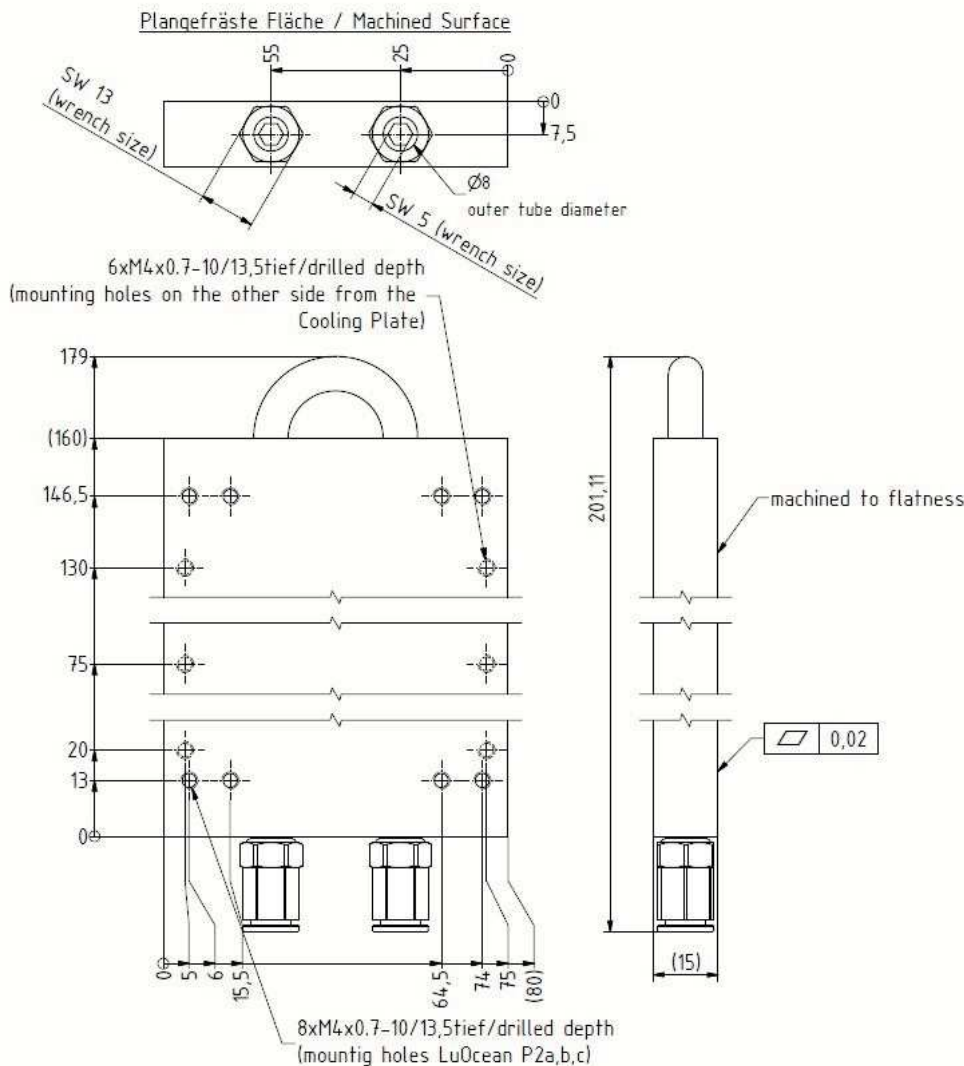

User Safety

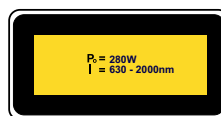

Important Note Read and carefully follow operating manual instructions. Especially, whenever power supply is switched on or off, always disconnect from laser module. See manual for details. Uncontrolled on / off switching may cause spikes and result in fatal device damage. This product is not certified by IEC 60825-1 or 21CFR1040.10/21CFR1040.11 and must comply with the applicable regulations by the Purchaser if sold as laser product.

We manufacture diode lasers.