



808nm, 2.5 Watt HHL Packaged Laser Diode; Fiber Coupled Module

- 2.5 Watts of Output Power
- 808nm (± 3 nm) Center Wavelength
- Fiber Core 62.5 μ m
- Numerical Aperture 0.22NA
- Integrated TE Cooler, Thermistor and Monitor PD
- High Efficiency Fiber Coupling

RL8082.5W DATA SHEET



WORLD LEADING PRODUCTS
FOR LASER SCIENTISTS AND ENGINEERS

DATA SHEET

RL8082.5W Product Overview

These 808nm, 2.5 Watt laser diodes are offered in a fiber coupled package with integrated TE cooler, thermistor and monitor PD. These devices are commonly used in applications such as materials processing, medical use, and solid-state laser pumping. They are offered with a 62.5 um core fiber and SC/APC connector. The fiber has a 2mm jacket for protection.

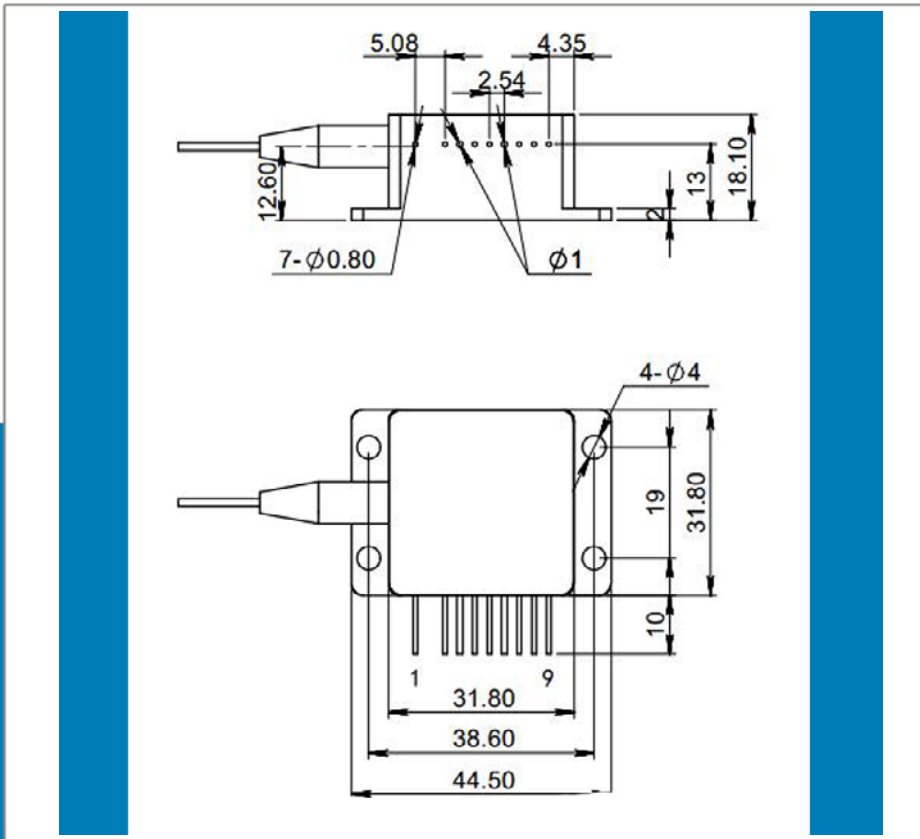

RL8082.5W SPECIFICATIONS

SPECIFICATIONS

Center Wavelength:	808 nm
Center Wavelength Tolerance:	±3 nm
Spectral Width:	<3nm
Rated Optical CW Output Power:	2.5 Watts
Threshold Current:	500 mA
Forward Current:	< 4.5 Amps
Forward Voltage:	< 2.5 Volts
TEC Current:	Max 7.5 Amps
TEC Voltage:	Max 2.8 Volts

FIBER SPECIFICATIONS

Fiber Core:	62.5 um, 0.22 NA
Fiber Length:	2 meters
Connector:	SMA905



DATA SHEET

Pins	Function
1	TEC (-)
2	Case
3	Laser (+)
4	Thermistor
5	Thermistor
6	Laser (-)
7	PD (P)
8	PD (N)
9	TEC (+)

Product Warranty:

In addition to the standard full one year warranty, this product is offered with an additional 3 months of extended warranty for a total of 15 months of warranty coverage. The warranty includes all parts and labor. The warranty does not include customer induced product damage.

Our Customer Commitment:



You Get Direct, Fast Tech-Support from a Product ENGINEER ... Not a Sales Person

You get DIRECT access to the correct factory engineer for your product. We eliminate the sales person "middle-man" back and forth time delays resolving technical issues. No more "Contact Us" forms. Every product has an assigned engineer in our auto-messaging data base to give you direct, immediate access to the correct tech-support info.



You Get an Extended Warranty

All products from Laser Lab Source come with a 12 month factory warranty. Additionally, we offer and extra 3 months of warranty on top of the standard warranty. *Warranty does not include customer induced product damage.*



You Get the Lowest Factory-Direct Prices Worldwide

All of our 3rd party global suppliers set & quote their own direct pricing. There are NO Mark-Up's. You get their lowest direct price.