



*This product is sold
and supported
in the USA by*



LASER LAB SOURCE
marketplace for **Scientists & Engineers**

Laser Diode Part Number: 1030LD-1-0-0

contact@laserlabsource.com | 800-887-5065

1030 nm laser diode

200 mW (CW) / 1200 mW (Pulsed) / singlemode fiber / Butterfly package

Reference: 1030LD-1-0-0

Technology : Single mode Fabry Perrot*

SPECIFICATIONS	Unit	Min	Typ	Maximum
Output Power (CW)	mW	150	200	
Output Power (Pulsed)	mW	1000	1200	
Center Wavelength	nm	1025	1030	1045
Spectral Width (CW/Pulse)	nm(FWHM)			0.2/1.0
Threshold Current	mA		60	80
Operating Current (CW/Pulse)	mA		350/2500	
Operation Voltage	V		1.6	2.0
Wavelength shift w Temperature	nm/°C		0.35	
Power in Band	%	90		
Polarization Extinction Ratio	dB	13		
Internal Photodiode Responsivity	mA/W	0.5		10
Internal Photodiode Dark Current	nA			100
TEC current (Case @ 75°C)	A			1.5
TEC Voltage (Case at 75°C)	V			3.3
Internal thermistor (25°C)	kOhm	9.5		10.5
Fiber type	PM fiber : SM98-PS-U25D-H or Nufern PM980			
Fiber bend radius	mm	16 (abs min)		
Coating diameter	µm		250/900	
Storage case temperature	°C	-40 (abs. min)		85 (abs. max)
Operating case temperature	°C	-5 (abs. min)		75 (abs. max)
Lead soldering temperature	°C			280
Laser diode reverse voltage	V			2.0
Pigtail termination	Ferrule			
Polarization state	Aligned to the slow axis			

*See our tutorial on [fiber coupled laser diode](#)

Form factor:

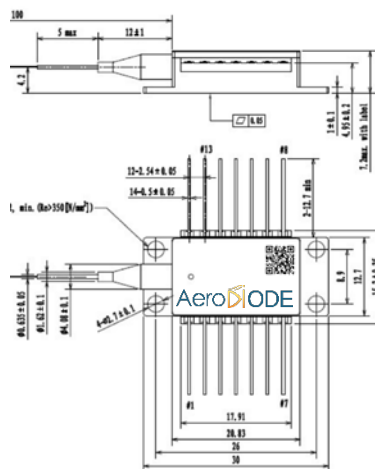

Dimensions are in mm

Laser diode pinning :

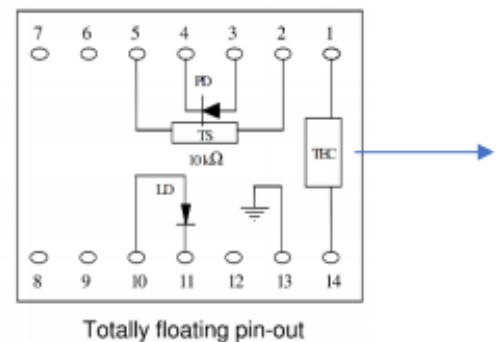

Totally floating pin-out