

200 W Fiber-Coupled Diode Pump Laser Module

ST Series: ST2



ST2 delivers 200 W of power within 0.15 numerical aperture of 135 μm core fiber leveraging the industry-proven track record of Lumentum ST Series high-brightness pump laser family. It uses a new generation of high-power proprietary chip optimized for reliability at high power. The 200 W laser also supports the “build-your-own” kilowatt (kW) laser market.

The multimode pump module offers high brightness, small size, and simplified thermal management. The diode operates as distributed heat sources, allowing air- or water-cooled architectures with predictable high reliability.

The ST Series is a unique solution for the fiber-coupled pump-laser market, offering powerful technical attributes in a cost-effective package.

Key Features

- 200 W output power into 0.15 numerical aperture (NA) of 135 μm core
- 915 nm wavelength
- High reliability
- 1060 nm feedback protection
- 0.22 numerical aperture (NA) fiber
- Isolated electrical contacts

Applications

- Fiber laser pumping
- Material processing

Dimensions Diagram

(Specifications in mm unless otherwise noted.)

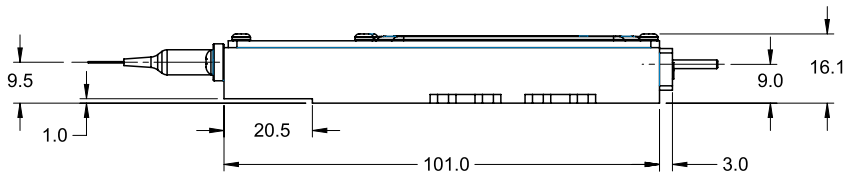
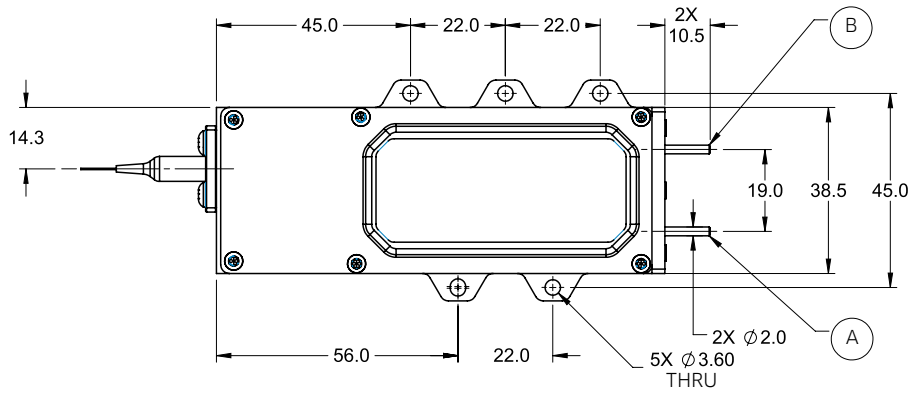
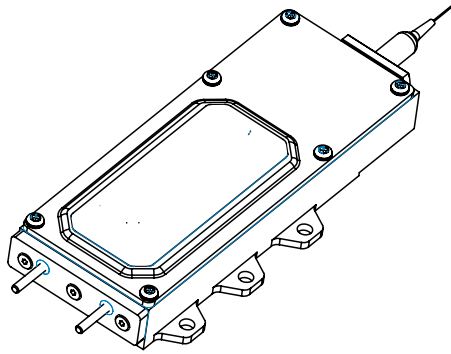

Pinout

| Pin | Description |
|-----|-------------------|
| A | Laser cathode (-) |
| B | Laser anode (+) |

Specifications¹

| Parameter | Symbol | Minimum | Typical | Maximum |
|--|--------------------------|---------------------|-------------------|---------------------|
| Laser Characteristics at 200 W Output Power | | | | |
| Maximum operating current set point (BOL) | $I_{op,max}$ | — | — | 18.0 A |
| Laser Characteristics at 16.5 A (BOL) | | | | |
| Maximum operating voltage | $V_{op,max}$ | — | — | 25.0 V |
| Electrical-to-optical conversion efficiency | PCE | 45% | 52% | — |
| Wavelength range (98% of power within band) | λ | 910 nm | — | 930 nm |
| Wavelength shift with temperature | $\Delta\lambda/\Delta T$ | — | 0.3 nm/°C | — |
| Back reflection isolation 1060-1100 nm | | 30 dB | — | — |
| Light within 0.15 NA | | — | 95% | — |
| Fiber Characteristics | | | | |
| Fiber core diameter (Nufern P/N MM-S135/155-22FA) | d_c | 133.5 μm | 135 μm | 136.5 μm |
| Fiber numerical aperture | NA | 0.20 | 0.22 | 0.24 |
| Fiber cladding diameter | d_{cl} | 153 μm | 155 μm | 157 μm |
| Fiber buffer diameter ² | d_B | 300 μm | 320 μm | 340 μm |
| Fiber loose tubing diameter (PN 22136721 only) | d_l | 0.75 mm | — | 1.05 mm |
| Total fiber length | Lf | 1.2 m | — | 2.0 m |
| Fiber loose tubing length (PN 22136721 only) | Lt | 0.7 m | — | 0.9 m |
| Fiber bend radius | | 35 mm | — | — |
| Fiber termination | | — | None | — |
| Fiber axial pull force, 15 s | | — | — | 5 N |
| Fiber side pull force, 15 s | | — | — | 2.5 N |

1. All electrical and optical performance data referenced at 35°C (case temperature) and $I_{op}=16.5\text{A}$, Beginning of Life (BOL), unless otherwise specified.

2. Low index coating.

Note:

Cold plate typically needs to be chilled to 25°C-30°C to maintain 35°C pump case temperature.

Environmental Requirements

| Parameter | Minimum | Maximum | Notes |
|--|---------|---------|--|
| Case operating temperature (base of laser housing) | 10°C | 50°C | Mounting feet can be used to approximate base temperature. |
| Storage and transportation temperature (non-operating) | -30°C | 75°C | Non-condensing under operation and storage. |
| Electrostatic discharge (ESD) | — | 500 V | HBM |
| Maximum voltage between any pin and package | — | 85 V | |
| RoHS 6/6 | | | Compliant |

Operating Considerations

Operating the diode laser outside at maximum ratings may cause device failure or a safety hazard. Power supplies used with the component must be employed so that the maximum peak optical power cannot be exceeded. CW diode lasers may be damaged by excessive drive current or switching transients. When power supplies are used, the diode laser should be connected with the main power on and the output voltage at zero. The current should be increased slowly while the diode laser output power and the drive current are monitored.

Device degradation accelerates with increased temperature, and thus the case temperature should be minimized and the unit operated in a non-condensing atmosphere.

A proper heatsink for the diode laser on a thermal radiator will greatly enhance laser life. Refer to the product application note for more information regarding heat sinking and mounting the product.

Electrostatic Discharge (ESD) Protection

ESD is the primary cause of unexpected diode-laser failure. Take extreme precaution to prevent ESD. Use wrist straps, grounded work surfaces, and rigorous antistatic techniques when handling diode lasers.

Laser Safety

DANGER

Invisible laser radiation. The laser beam emitted from this diode laser is invisible and can cause serious injury. Avoid looking directly into the diode laser or the collimated laser beam along its optical axis when the device is in operation. Avoid reflected or scatter radiation. Use protective eyewear properly selected for the laser beam wavelength and maximum power.

Viewing the laser output with certain optical instruments (e.g., eye loupes, magnifiers, and microscopes) will increase eye hazards.



Labeling

This diode-pumped laser module is not 21CFR 1040.10 or IEC 60825-1:2007 certified. It is a component intended for system integration. Compliance with 21CFR 1040.10 and/or IEC 60825-1:2007 will need to be determined at the system level.

Serial Number Identification Label



Ordering Information

For more information on this or other products and their availability, please contact your local Lumentum account manager or Lumentum directly at customer.service@lumentum.com.

| Description | Part Number |
|---|-------------|
| 200 W Fiber-coupled diode pump laser module, 910-930 nm, without loose tubing | 22136816 |
| 200 W Fiber-coupled diode pump laser module, 910-930 nm, with loose tubing | 22136721 |



North America
Toll Free: 844 810 LITE (5483)

Outside North America
Toll Free: 800 000 LITE (5483)

China
Toll Free: 400 120 LITE (5483)

© 2020 Lumentum Operations LLC
Product specifications and descriptions in this document are subject to change without notice.