



Offered by
LASER LAB SOURCE

manufactured by  **COHERENT**

Turn-Key Violet Laser Source System 405nm, 250mW Free-Space Output

INDUSTRY LEADING BEAM QUALITY & STABILITY
spatial mode TEM₀₀ | RMS noise \leq 0.05%



SIMPLE, ALL INCLUSIVE TURN-KEY OPERATION
laser price includes current/temp controller & all cables

OBIS 405nm, 250mW Free-Space SKU: 1303773

- o Laser Diode Reliability, and Fast Modulation
- o High Quality, Low-Asymmetry Beam Profile
- o Analog and Digital Modulation Capable
- o Ideal for Laser Systems that Require Multiple Analytical Wavelengths
- o Fast and Easy Setup, Turn-Key Operation
- o Remotely Operated via USB and RS-232 Interface, Software Included



BEST-IN-CLASS VIOLET LASER SOURCE

Coherent's industry-leading violet laser diode laser technology delivers outstanding beam quality and output stability, and provides the best-in-class laser reliability and performance. These laser systems are shipped ready-to-run with the power supply and remote controller, and all the required cables and accessories.

INDUSTRY-LEADING OUTPUT QUALITY

The hallmarks of the OBIS laser system design are best-in-class low noise performance, high stability and beam quality, and long-term reliability. The benefits to your application may include: enhanced measurement accuracy, reduced measurement error, reduced coefficient of variation, and laser-sharp microscope images.

LASER MODULE

Laser exit aperture;
M6 x 0.75 threaded for
attachment of optional
bandpass filter



Mechanical shutter
for laser safety

Laser status
indicator

OBIS LASER MODULE CONTROL UNIT (INCLUDED)

Laser enable
safety keyswitch

Laser status
indicators



Safety
interlock

Illuminated power
ON/OFF switch

LONG-TERM SYSTEM RELIABILITY BY DESIGN

The OBIS controller integrates multiple internal safety features to ensure a long operating lifetime, and external safety features help protect the user during laser operation. A connector is included for driving a cooling fan, and the laser head can be mounted to the OBIS heatsink for easily configured temperature stabilization.

OBIS LASER CONTROLLER REAR PANEL

Input from 12VDC power supply;
power supply included

RS232 & USB
I/O connectors

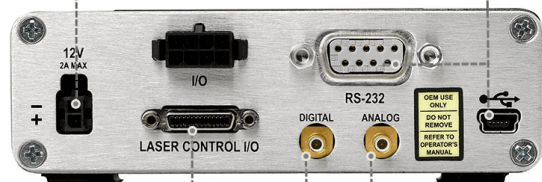

Output to laser module;
1 meter connecting
cable included

SMA connectors;
digital & analog
modulation inputs

COMPACT REMOTE CONTROLLER

The OBIS system includes a compact, full-featured laser module controller. The controller can be operated via USB or RS232 and the included software, includes analog and digital modulation inputs, front-panel operating status lights, and an illuminated laser ON / OFF power switch. The safety interlock and keyswitch enhance safety for the operator.



VERSATILE MODULATION CAPABILITY

The OBIS laser system can be operated in CW mode, or modulated with analog and digital signals. The laser can be modulated to full-off output, ensuring no photons are emitted. LS modules can be modulated to full-off output using the digital modulation mode. The LX modules can be modulated to full-off using the analog modulation mode with a software-enabled Blanking feature.

UNMATCHED TURN-KEY CONVENIENCE

The OBIS turn-key system is truly complete, and includes everything necessary to be up and running within minutes of unboxing the system: the remote controller, power supply, I/O cable to connect the controller to the laser head, controller mounting hardware, color coded labels for easy controller identification in multi-wavelength systems, and the controller software on a flash drive.

A TRUE TURN-KEY SOLUTION



the full kit includes: mounting hardware, laser controller, cables, power supply, and color-coded labels to instantly identify controllers in multi-wavelength applications

EASILY BUILD MULTI-WAVELENGTH SYSTEMS

The OBIS laser systems are ideal for applications that require multiple wavelengths. The controllers are securely stack-mounted using the included mounting hardware, and the USB connectivity provides stress-free operation of multiple systems from a single computer. The days of

piecing together lasers from multiple different manufacturers are over, replaced by the cost-saving convenience of the OBIS series.

SIMPLIFY MULTI-WAVELENGTH SYSTEMS

control multiple controllers simultaneously using Coherent's software and the convenience of USB



multiple controllers can be securely stacked using the included mounting hardware

AVAILABLE BANDPASS FILTERS

For applications that are sensitive to longer wavelength emissions, bandpass filters are available to help improve the detection signal to noise ratio. Filters are available at 445nm, 473nm, 488nm, 633nm, and 640nm, and attach directly to the front of the laser head.



OPTIONAL BANDPASS FILTER

Threaded for attachment to OBIS free-space head



OBIS FREE-SPACE LASER SYSTEM - COMPLETE PERFORMANCE SPECIFICATIONS

OUTPUT SPECIFICATIONS

- Wavelength: 405 nm (\pm 5 nm)
- Wavelength Color: Violet
- Output Power: 250 mW, User Adjustable
- Technology: Laser Diode
- Warm-Up Time: 5 min
- Laser Drive Modes: CW, Analog Modulation, Digital Modulation and Computer Control
- Other Output Powers Available: 50mW, 100mW, 200mW, 365mW

OPTICAL BEAM AND OUTPUT SPECIFICATIONS

- M^2 Beam Quality: \leq 1.2 (50mW, 100mW; *Beam Quality at 90/10 Clip Levels*)
- M^2 Beam Quality: \leq 1.3 (200mW, 250mW, 365mW, *Beam Quality at 90/10 Clip Levels*)
- Beam Asymmetry: \leq 1:1.2
- Spatial Mode: TEM₀₀
- Beam Type / Shape: Circular Beam
- Beam Diameter at $1/e^2$: 0.8 \pm 0.1 mm
- Beam Divergence (full-angle): $<$ 1 mrad
- Pointing Stability (over 2 hours after warm-up and \pm 3°C): $<$ 30 μ rad
- Pointing Stability Over Temp.: $<$ 5 μ rad/°C
- RMS Noise, 20 Hz to 20 MHz: \leq 0.05 %
- Peak to Peak Noise, 20 Hz to 20 kHz: $<$ 0.5 %
- Long Term Power Stability (8 hrs, \pm 3°C): $<$ 2 %
- Polarization Ratio: Minimum 100:1, Vertical \pm 5°
- Warm-Up Time, from Cold Start: $<$ 5 min.
- **Static Alignment Tolerances**
- Beam Position from Reference: $<$ 1 mm *
- Beam Angle: $<$ 5 mrad *
- Beam Waist Position at Exit Window: n/a
- * See Mechanical Drawing for Beam Exit Location



MODULATION SPECIFICATIONS

- **Digital Modulation**
- Connector: SMB, 0 V to 3 V, 50 Ω input impedance
- Maximum Bandwidth: 150 MHz
- Rise Time (10% to 90%): < 2 nsec
- Fall Time (90% to 10%): < 2 nsec
- Modulation Extinction Ratio: >1,000,000:1 at 0 Hz, >250:1 at 150 MHz
- **Analog Modulation**
- Connector: SMB, 0V to 5V, 50 Ω or 2000 Ω input impedance
- Maximum Bandwidth: 500 kHz
- Rise Time (10% to 90%): < 700 nsec
- Fall Time (90% to 10%): < 700 nsec
- Modulation Extinction Ratio: > 1,000,000:1

GENERAL SPECIFICATIONS

- Laser Safety Classification: 3b
- ESD Protection: EN61326-1
- Power Consumption: 5 W (typ), 13 W (max)
- Max Laser Head Baseplate Temperature: 50°C (LX versions)
- Max Laser Head Baseplate Temperature: 40°C (LS versions)
- Operating Temperature: 10°C to 50°C (non condensing)
- Storage Temperature: -20°C to 60°C (non condensing)

UTILITY AND ENVIRONMENTAL REQUIREMENTS

- Operating Voltage: 12 VDC
- Safety: Key-Switch and Interlock Connection
- Laser Head Dimensions: 70 x 40 x 38 mm (2.75 x 1.57 x 1.5 in.)
- OBIS Remote Dimensions: 105 x 68 x 36 mm (4.13 x 2.68 x 1.42 in.)
- DC Power Supply Dimensions: 105 x 42 x 33 mm (4.13 x 1.65 x 1.3 in.)
- Laser Head Weight: 0.16 kg
- OBIS Remote Weight: 0.23 kg (0.5 lb)
- DC Power Supply Weight: 0.36 kg (0.79 lbs.)
- USB Control Interconnection: USB 2.0, Mini-B
- RS-232 Control Interconnection: RS-232, 11.2 k
- Remote to Laser Connection: 1 m Cable, included
- Shock Tolerance (6 msec): 30 g



OBIS LX/LS FREE-SPACE LASER DIODE SOURCE MODULE DIMENSIONS

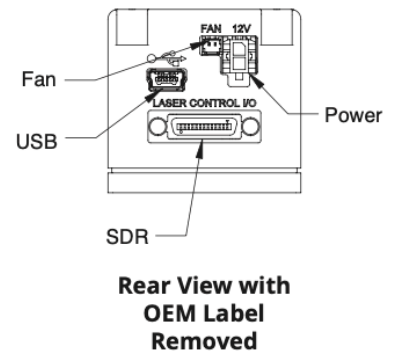
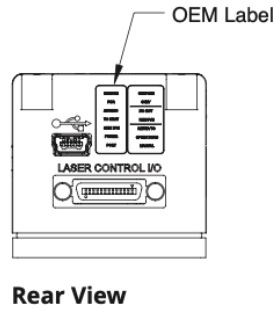
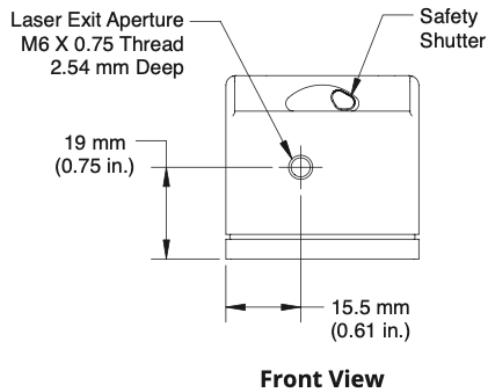
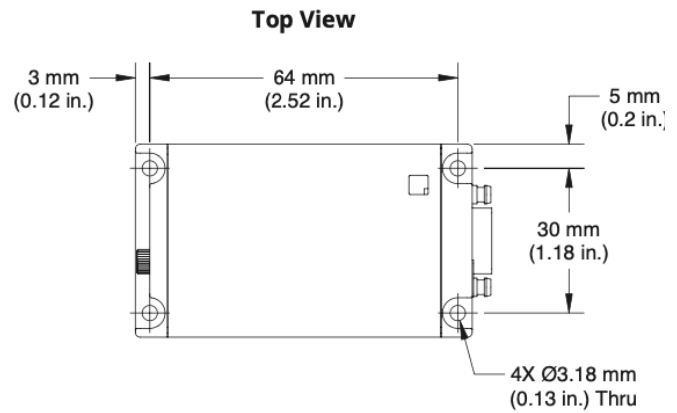
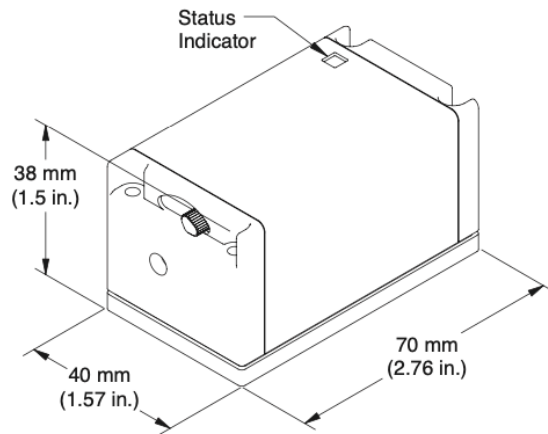



OBIS SYSTEM OPTIONS AND ACCESSORIES

The OBIS laser systems are available with a wide range of accessories to expand the functionality of the systems and improve your productivity.

FAN-COOLED HEATSINK

The fan-cooled heatsink provides an inexpensive and effective way to mount the OBIS laser in a wide range of applications, and remove waste heat for stable output. The 12 V fan connects directly to the fan control output on the OBIS laser head.



SIX-LASER SIMPLE REMOTE CONTROLLER

A basic six-laser controller is available for CW applications where simplified benchtop control is required. The lasers can be controlled via illuminated on/off switches, and the laser heads can be interfaced by the USB connections on the heads.



FULL-FEATURED SIX-LASER REMOTE CONTROLLER

The full-featured scientific benchtop controller provides independent control of up to six LS/LX laser heads, and includes modulation inputs on the instrument front face. The controller is operated via the front-panel touch screen, USB, RS-232, or Ethernet interface.



INTEGRATED FIVE-LASER SYSTEM

The five-laser mounting system provides thermal management, cooling fans, analog and digital modulation inputs, and computer control interface all in one convenient box. The five-laser system streamlines development and deployment of multi-wavelength analytical systems by combining all the critical control functions in one compact format.





Offered by
LASER LAB SOURCE



**LIGHT
SOURCES**

PRODUCT SALES AND SERVICE:

Unlimited phone and email support is provided for products purchased through Laser Lab Source. Orders for this product are fulfilled by Laser Lab Source in North America and select international regions. It is manufactured by Coherent, California, USA.

PRODUCT WARRANTY:

This product is sold with a full one-year warranty. It is warrantied to be free from defects in material and/or workmanship for a period of one year from the date of shipment.



Laser Lab Source, a division of Research Lab Source, Inc.
670 S. Ferguson St., Suite 3
Bozeman, MT 59718 USA

Phone: 406-219-1472

www.LaserLabSource.com



Coherent, Inc.,
5100 Patrick Henry Drive
Santa Clara, CA 95054