

976nm, Conduction-Cooled Single Bars

Features

- Very low smile
- Available with fast-axis collimation
- Different heatsink geometries available



Device Specification

Optical Parameters ¹	Units	
Center Wavelength Range ³	nm	976
Center Wavelength Tolerance	nm	±3
Output Power ² (P _{OP})	W	60
Number of Emitters	#	19
Emitter Size	µm	100
Fill Factor	%	20
Spectral Width (FWHM)	nm	<5
Slope Efficiency	W/A	>0.95
Fast-Axis Divergence ⁵ (90%)	degree	<46
Slow-Axis Divergence (90%)	degree	<7.5
Wavelength Temp. Coefficient	nm/°C	~0.38

Electrical Parameters ¹		
Power Conversion Efficiency	%	>58
Threshold Current (I _{TH})	A	<7.5
Operating Current (I _{OP})	A	70
Operating Voltage (V _{OP})	V	<1.7

Thermal Parameters ¹		
Operating Temperature Range ⁴	°C	+20 to +30
Storage Temperature Range ⁴	°C	0 to +55
Recommended Heatsink Capacity Per Bar	W	>70

¹Data at 25°C cold plate temperature, unless otherwise stated.

²Reduced lifetime if used above nominal operating conditions.

³Others available upon request.

⁴A non-condensing environment is required for storage and operation below the ambient dew point.

⁵For fast-axis collimation using FAC lens: divergence <8mrad.

976nm, Conduction-Cooled Single Bars

Package Dimension

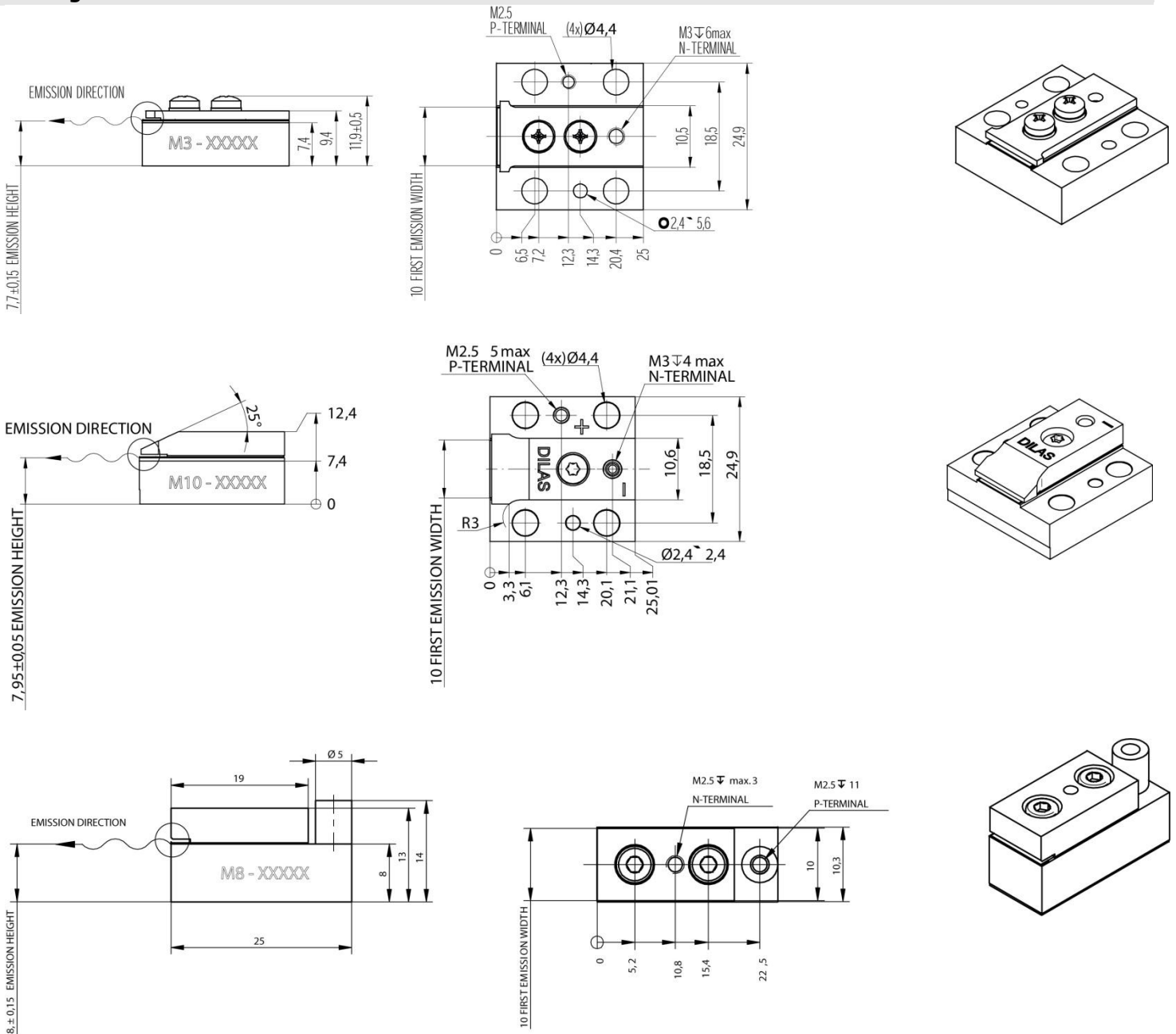

Heatsink for MY Diode Laser Bars with Fast-Axis Collimation Lens:

Beam heights available:

- M3 mount = 7.7mm
- M10 mount = 7.95mm
- M8 mount = 8.0mm

Upon request:

- M7 mount = 6.0mm

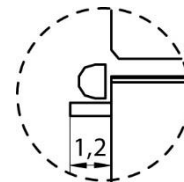

©2012 DILAS. All rights reserved. DILAS reserves the right to change product specifications without notice. For handling precautions, please reference the general handling instruction manual.

For complete details, please contact your local DILAS sales representative or visit our website at www.DILAS.com.

Europe
DILAS Diodenlaser GmbH
Galileo-Galilei-Straße 10
55129 Mainz
Germany
Phone: +49 (0)6131 9226 0
Fax: +49 (0)6131 9226 257
Email: sales@DILAS.de

North America
DILAS Diode Laser, Inc.
9070 South Rita Road
Suite 1500
Tucson, AZ 85747
Phone: +1 (520) 232-3480
Fax: +1 (520) 232-3499
Email: sales@DILAS-INC.com

China & Taiwan
DILAS Diodenlaser GmbH
China Sales Office
Room 206, Sunplus Technology, Bldg. 2
No. 1077 Zu Chongzhi Road
Hi-Tech Park, Shanghai 201203,
P.R. China
Phone: +86 (0) 21-6855-2216
Fax: +86 (0) 21-5027-3793
Email: sales@dilas-china.com.cn