

976nm, 200µm, Conduction-Cooled, Narrow Linewidth, Fiber-Coupled Multi-Bar Module

Features

- Narrow linewidth of <1nm
- High coupling efficiency
- High brightness
- Conduction-cooled
- Sealed housing

Optional Accessories

- Integrated pointer laser
- Integrated power meter
- Integrated NTC temperature sensor
- Fiber detection sensor



Device Specification

Optical Parameters ¹	Units		
Center Wavelength Range ³	nm	976	976
Center Wavelength Tolerance	nm	±0.6	±0.6
Output Power ²	W	120	180
Spectral Width (FWHM)	nm	<1	<1
Slope Efficiency	W/A	>2.8	>4.2
Wavelength Temp. Coefficient	nm/°C	~0.01 ⁵	~0.01 ⁵

Fiber Parameters			
Numerical Aperture	NA	0.22	0.22
Fiber Core Diameter	µm	200	200
Fiber Connector		HP-SMA 905 with Free Standing Fiber Tip	QBH

Electrical Parameters ¹			
Power Conversion Efficiency	%	>35	>35
Threshold Current (I _{TH})	A	<7.5	<7.5
Operating Current (I _{OP})	A	<55	<55
Operating Voltage (V _{OP})	V	<8	<12

Thermal Parameters			
Operating Temperature ^{3, 4}	°C		+20 to +30
Storage Temperature ⁴	°C		0 to +55
Recommended Heatsink Capacity	°C	>320	>480

¹Data at 25°C cold plate temperature, unless otherwise stated.

²Reduced lifetime if used above nominal operating conditions.

³Others available upon request.

⁴A non-condensing environment is required for storage and operation below the ambient dew point.

⁵Within operating temperature ±3°C

976nm, 200µm, Conduction-Cooled, Narrow Linewidth, Fiber-Coupled Multi-Bar Module

Package Dimension

HP-SMA 905 Fiber Connector

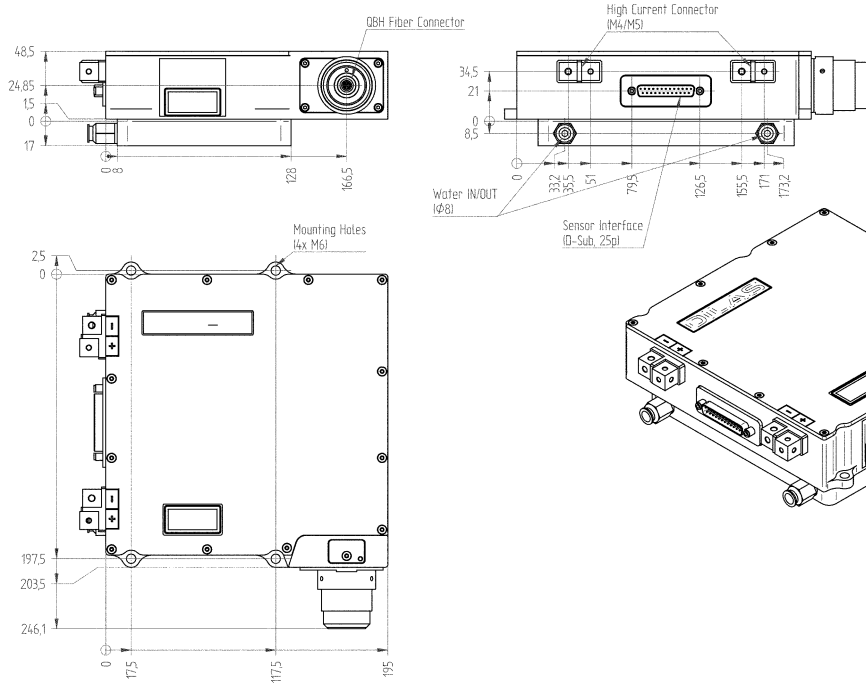
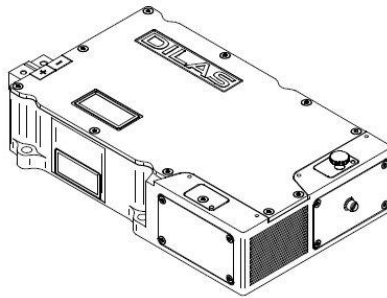
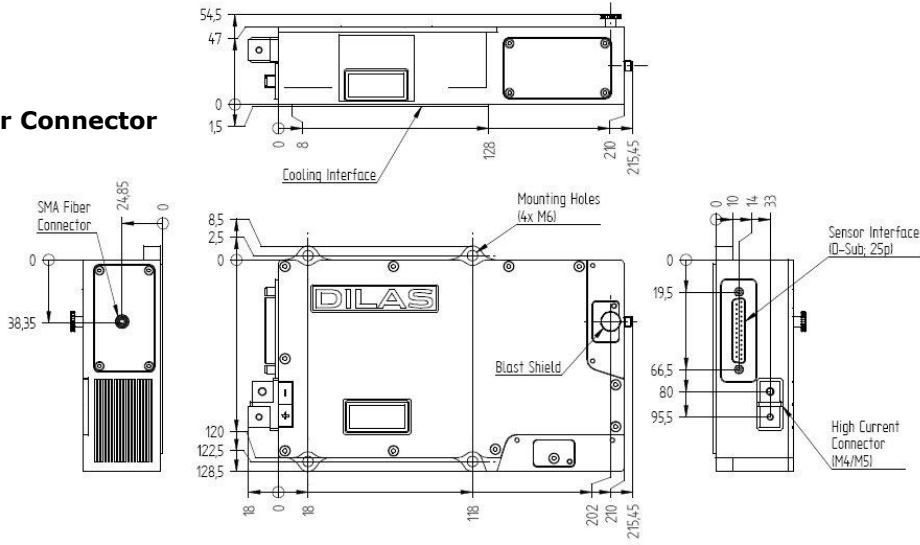

QPH Fiber Connector

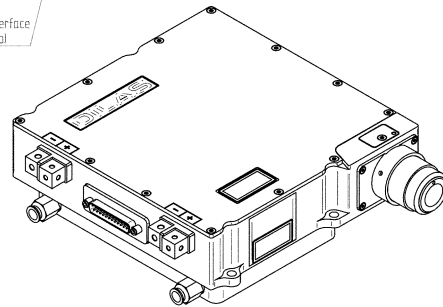

©2012 DILAS. All rights reserved. DILAS reserves the right to change products specifications without notice. For handling precautions, please reference the general handling instruction manual.

For complete details, please contact your local DILAS sales representative or visit our website at www.DILAS.com.

Europe
DILAS Diodenlaser GmbH
Galileo-Galilei-Straße 10
55129 Mainz
Germany
Phone: +49 (0)6131 9226 0
Fax: +49 (0)6131 9226 257
Email: sales@DILAS.de

North America
DILAS Diode Laser, Inc.
9070 South Rita Road
Suite 1500
Tucson, AZ 85747
Phone: +1 (520) 232-3480
Fax: +1 (520) 232-3499
Email: sales@DILAS-INC.com

China & Taiwan
DILAS Diodenlaser GmbH
China Sales Office
Room 206, Sunplus Technology, Bldg. 2
No. 1077 Zu Chongzhi Road
Hi-Tech Park, Shanghai 201203,
P.R. China
Phone: +86 (0) 21-6855-2216
Fax: +86 (0) 21-5027-3793
Email: sales@dilas-china.com.cn