

LD-10XX-BA-6W

High Power Diode Laser on open heatsink



Features:

- 6W output power at 1064nm
- Available wavelength range 1000-1130nm
- Proprietary mirror coating technology enabling high reliability
- Reliable Au/Sn bonding of chip to C-mount open heatsink
- For QCW operation TO-can packaging is possible
- RoHS compliance

SPECIFICATIONS

Test conditions: heatsink temperature 25°C

Parameters	Symb.	Min.	Typ.	Max.	Unit
Operating output power	P _{out}	6			W
QCW output power (200µs pulse width, 1% duty cycle)	P _{qcw}	12			W
Range of available wavelength	λ	1030	1064	1125	nm
Mean wavelength tolerance				5	nm
Spectral width @ -3dB level at P _{out}	Δλ		4	8	nm
Wavelength temperature tunability	Δλ/ΔT	0.3	0.4	0.45	nm/°C
Threshold current	I _{th}		0.45	0.7	A
Operating current at P _{out}	I _{op}		7.3	8.5	A
Forward voltage at P _{out}	V _f		1.6	1.9	V
Divergence parallel to p-n junction (FWHM)	Θ	4	8	11	deg.
Divergence perpendicular to p-n junction (FWHM)	Θ _⊥	31	33	35	deg.
Aperture size			90 × 1		µm × µm

TYPICAL PERFORMANCE for reference only*

Test conditions: CW operation, heatsink temperature 25°C

Light-Current-Voltage Characteristics

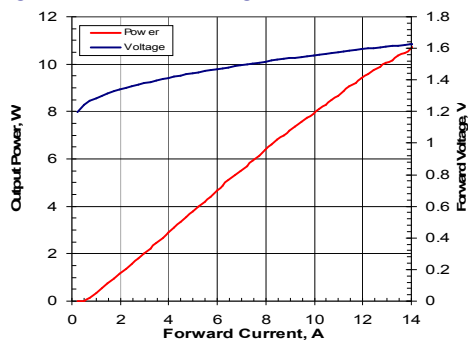

Spectral Characteristics

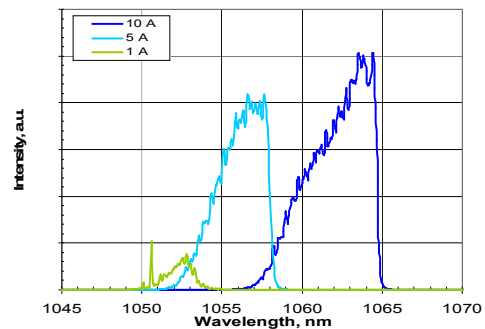

CW Slow Axis Far Field

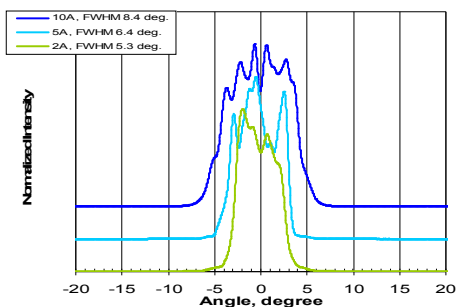

CW Fast Axis Far Field

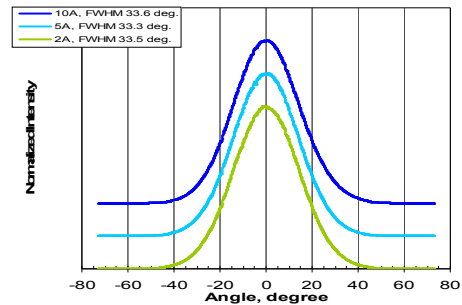

* Performance is given for the 1064nm device. Similar performance is expected for the other wavelengths in the 1000-1130nm range.

ABSOLUTE MAXIMUM RATINGS			
Parameters	Min.	Max.	Unit
Laser Diode reverse voltage	-	2	V
Laser Diode CW forward current	-	10p+4	A
Lead soldering temperature		250 (5sec.)	°C
Operating temperature range	above dew point	60	°C
Storage temperature range	-40	85	°C

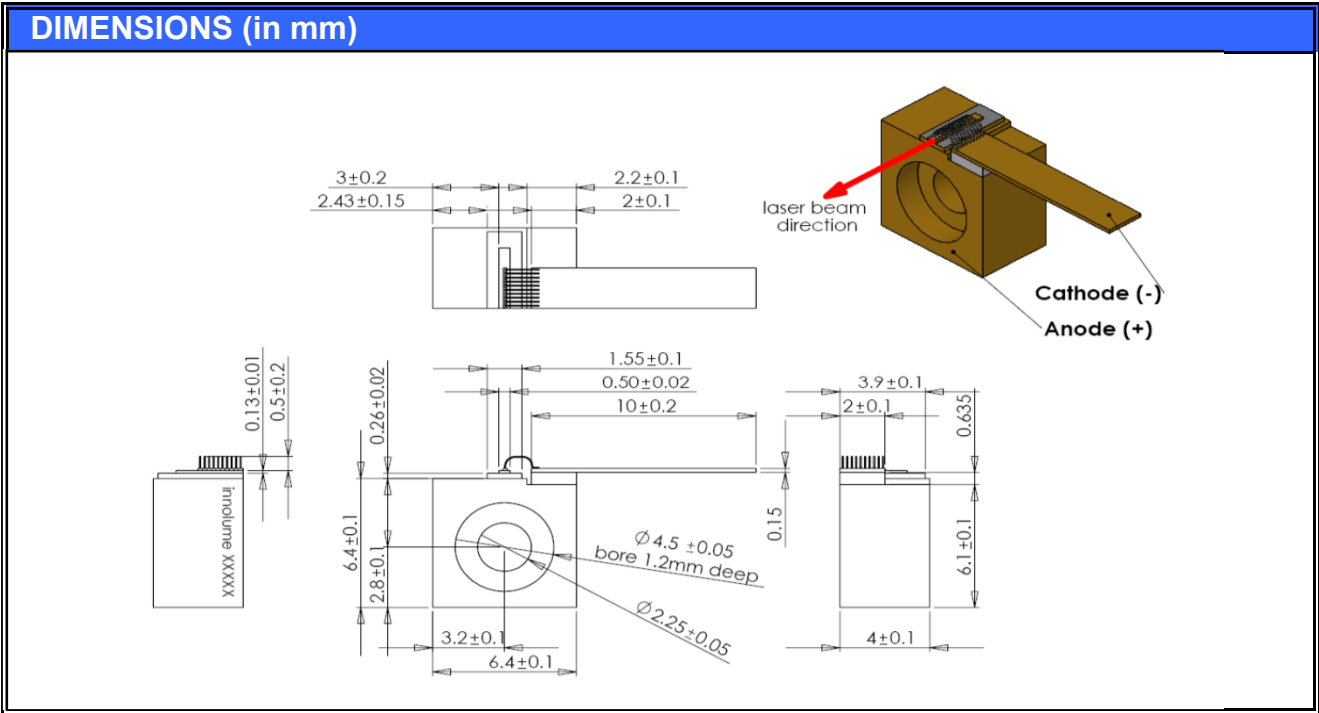

SAFETY AND OPERATING INSTRUCTIONS

The laser light emitted from this Device is invisible and will harmful to the human eye. Avoid looking directly into the fiber output or into the collimated beam along its optical axis when the device is in operation. Proper laser safety eyewear must be worn during operation. Absolute Maximum Ratings may be applied to the Device for short period of time only. Exposure to maximum ratings for extended period of time or exposure above one or more max ratings may cause damage or affect the reliability of the Device. Operating the product outside of its maximum ratings may cause device failure or a safety hazard. Power supplies used with the Device must be employed such that the maximum peak optical power cannot be exceeded. A proper heatsink for the Device on thermal radiator is required, sufficient heat dissipation and thermal conductance to the heatsink must be ensured. The Device is an Open-Heatsink Diode Laser; it may be operated in cleanroom atmosphere or dust-protected housing only. Operating temperature and relative humidity must be controlled to avoid water condensation on the laser facets. Any contamination or contact of the laser facet must be avoided.

ESD PROTECTION – Electrostatic discharge is the primary cause of unexpected product failure. Take extreme precaution to prevent ESD. Use wrist straps, grounded work surfaces and rigorous antistatic techniques when handling the product.



Example of Part Number Identification

LD-1064-BA-6W -> 6W output power at mean wavelength 1064nm

NOTE: Innolume product specifications are subject to change without notice