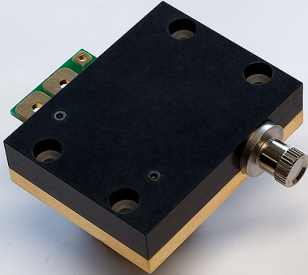

<b>LD-10XX-AK2-20W</b> High Power Diode Laser – multi-chip package	
	<p><b>Features:</b></p> <ul style="list-style-type: none"> <li>▪ Multi-chip package</li> <li>▪ High efficiency</li> </ul> <ul style="list-style-type: none"> <li>▪ Small form factor - 53 x 41 x 14 mm</li> <li>▪ Built-in thermistor</li> <li>▪ High power SMA 905 connector.</li> <li>▪ Designed for multimode fiber patch cords with core diameter of 400um and 0.22 NA</li> </ul>
<p><b>Specification</b> for engineering samples</p>	<p>DATE: 27<sup>st</sup> June 2013</p>

SPECIFICATIONS				
Test conditions: CW cooled operation at 25°C, output power 20W in CW operation. 400µm-core diameter NA0.22 patch-cord used for test.				
Parameters	Min.	Typ.	Max.	Unit
Ex-fiber optical output power	20			W
Mean wavelength (25°C case temperature)	1030	1064	1125	nm
Mean wavelength tolerance		5	10	nm
Wavelength temperature tunability	0.3	0.35	0.4	nm/°C
Spectral width (FWHM)		6	10	nm
Operating current		15	17	A
Threshold current		0.9	1.3	A
Forward voltage		3.0	3.5	V
Case operating temperature	20		60	°C
NTC thermistor @ 25°C		10		kΩ
Module heatload at max current			40	W

ABSOLUTE MAXIMUM RATINGS			
Parameters	Min.	Max.	Unit
Anode reverse voltage		1	V
Forward current		20	A
Storage temperature range	15	90	°C
Operating temperature range	20	60	°C

## DIMENSIONS

All sizes in mm

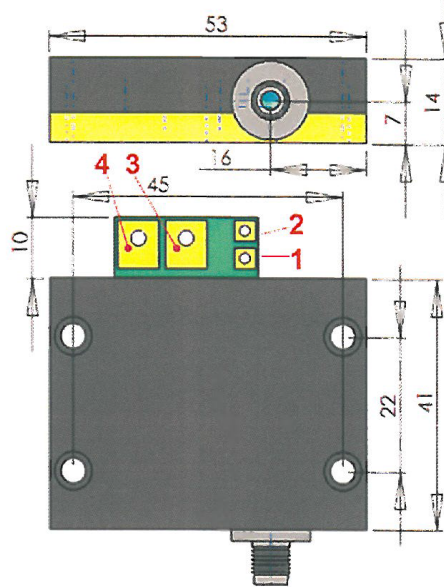

**Pin-out:** 1,2 – internal thermistor, 3 – Laser (+), 4 – Laser (-),  
**Mounting:** Four M3 or #4 mounting screws. Use TECs with cold side dimensions within 40.5mm x 40.5mm footprint.

### Cooling system requirements.

Active cooling system is recommended for heat dissipation from laser module. Active cooling system must have power capability of 2 times higher compare to the "Module Heatload" value. For temperature stabilized operation the cooling system should use internal temperature monitor. The wavelength position may be adjusted by changing temperature with the "Wavelength temperature tunability" coefficient. It is extremely important to have a smooth high quality radiator surface under the laser module. The deviation from flatness must be less than 0.05mm. It is necessary to apply a thermo-conductive film or paste between the laser module and the radiator surface. Thermo-conductive paste must be uniformly distributed over the bottom surface of the module. It is desirable to minimize the thickness of thermo-conductive film. This can be done by gently rubbing and pressing the module and the radiator against each other with the paste between them.

### SAFETY INFORMATION

The laser light emitted from this module is invisible and will harmful to the human eye. Avoid looking directly into the fiber output or into the collimated beam along its optical axis when the device is in operation. Proper laser safety eyewear must be worn during operation.

