



Fiber-Coupled Diode Lasers

cw, passively cooled, high brightness



JOLD-50-FC-11

Design 215721124

Features:

- High optical output power of 50 W cw
- Fiber core diameter: 105 μm
- NA 0.15
- Cooling via mounting plate
- Lifetime > 10,000 h, high reliability

Applications:

- Pumping of fiber lasers
- Material processing

Fiber-Coupled Diode Lasers

cw, passively cooled, high brightness

Specifications (Start of Life)

Product	JOLD-50-FC-11, Design 215721124			
Operation Mode	cw, pulsed			
Maximum Optical Output Power	50	50	50	W
Center Wavelength at 25 °C	915	938	958	nm
Center Wavelength Variation at 25 °C	5	5	5	nm
Typical Spectral Bandwidth (FWHM)	5	5	5	nm
Maximum Spectral Bandwidth (FWHM)	7	7	7	nm
Typical Operation Current	8.5	8.5	8.5	A
Maximum Operation Current	10.5	10.5	10.5	A
Typical Threshold Current	0.6	0.6	0.6	A
Maximum Threshold Current	0.8	0.8	0.8	A
Typical Slope	6.3	6.3	6.3	W/A
Minimum Slope	5.0	5.0	5.0	W/A
Typical Operating Voltage	16.5	16.5	16.5	V
Maximum Operating Voltage	20.0	20.0	20.0	V
Fiber Core Diameter	105 µm			
Cladding Diameter	125 µm			
Numerical Aperture	NA 0.15			
Fiber Length	2 m			
Fiber Far End	Cleaved pigtail			
Minimum Fiber Bending Radius	50 mm			
Power Inside the Cladding	< 5%, cladding mode stripper integrated			
Fiber Laser Feedback Protection	1030 ... 1100 nm, integrated filter			
Anode Connector	M4, Socket cap screws ISO 4762 (case isolated)			
Cathode Connector	M4, Socket cap screws ISO 4762 (case isolated)			
Operation Conditions	Non-condensing atmosphere			
Expected Lifetime	> 10,000 h (constant current), under qualification			
Cooling:				
Mounting	Via thermally conductive foil (thickness 25 ... 100 µm) on cooled surface			
Diode Laser Operating Temperature	15 ... 30 °C at temperature sensor			
Temperature Sensor	Hole for thermal sensor, 2.5 mm diameter			
Storage Temperature	-25 ... 70 °C			

See General User Information!

Options on request: transport fiber 105 µm, NA 0.22 (NA 0.15 effective), Design 215720124

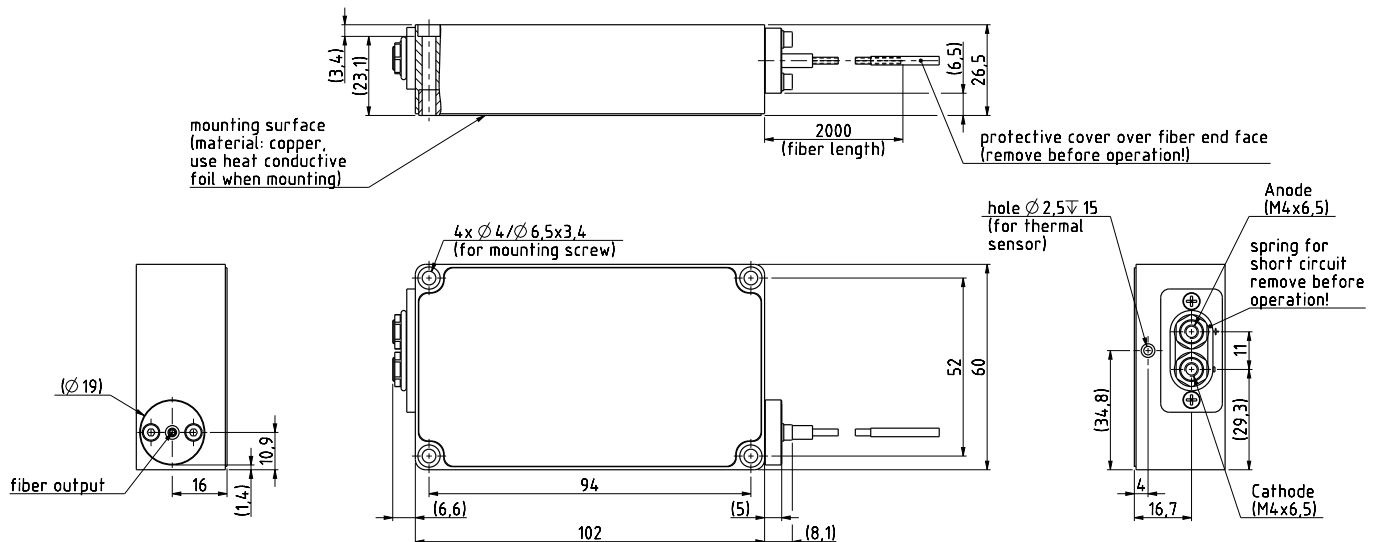

Specifications may change in compliance with our quality management system.

03/2011



JENOPTIK | Lasers & Material Processing

JENOPTIK Laser GmbH

Goeschwitzer Strasse 29 | 07745 Jena | Germany

Phone: +49 3641 65-3053 | Fax: +49 3641 65-4011

E-mail: sales-laser.lm@jenoptik.com | www.jenoptik.com/diodelasers



Fiber-Coupled Diode Lasers

cw, passively cooled, high brightness



JOLD-65-FC-11

Design 215721124

Features:

- High optical output power of 65 W cw
- Fiber core diameter: 105 μm
- NA 0.15
- Cooling via mounting plate
- Lifetime > 10,000 h, high reliability

Applications:

- Pumping of fiber lasers
- Material processing

Fiber-Coupled Diode Lasers

cw, passively cooled, high brightness

Specifications (Start of Life)

Product	JOLD-65-FC-11, Design 215721124			
Operation Mode	cw, pulsed			
Maximum Optical Output Power	65	65	65	W
Center Wavelength at 25 °C	915	938	958	nm
Center Wavelength Variation at 25 °C	5	5	5	nm
Typical Spectral Bandwidth (FWHM)	5	5	5	nm
Maximum Spectral Bandwidth (FWHM)	7	7	7	nm
Typical Operation Current	10.5	10.5	10.5	A
Maximum Operation Current	11	11	11	A
Typical Threshold Current	0.6	0.6	0.6	A
Maximum Threshold Current	0.8	0.8	0.8	A
Typical Slope	6.5	6.5	6.5	W/A
Minimum Slope	6.1	6.1	6.1	W/A
Typical Operating Voltage	16.5	16.5	16.5	V
Maximum Operating Voltage	20.0	20.0	20.0	V
Fiber Core Diameter	105 µm			
Cladding Diameter	125 µm			
Numerical Aperture	NA 0.15			
Fiber Length	2 m			
Fiber Far End	Cleaved pigtail			
Minimum Fiber Bending Radius	50 mm			
Power Inside the Cladding	< 5%, cladding mode stripper integrated			
Fiber Laser Feedback Protection	1030 ... 1100 nm, integrated filter			
Anode Connector	M4, Socket cap screws ISO 4762 (case isolated)			
Cathode Connector	M4, Socket cap screws ISO 4762 (case isolated)			
Operation Conditions	Non-condensing atmosphere			
Expected Lifetime	> 10,000 h (constant current), under qualification			

Cooling:	
Mounting	Via thermally conductive foil (thickness 25 ... 100 µm) on cooled surface
Diode Laser Operating Temperature	15 ... 30 °C at temperature sensor
Temperature Sensor	Hole for thermal sensor, 2.5 mm diameter
Storage Temperature	-25 ... 70 °C

See General User Information!

Options on request: transport fiber 105 µm, NA 0.22 (NA 0.15 effective), Design 215720124

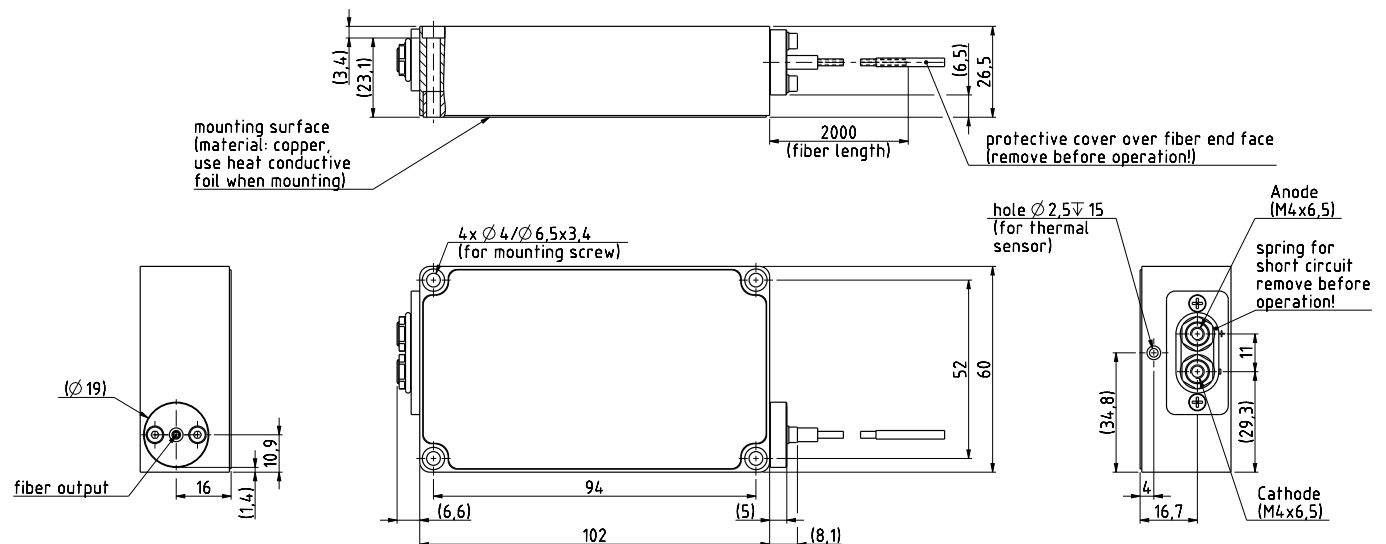

Specifications may change in compliance with our quality management system.

03/2011



JENOPTIK | Lasers & Material Processing

JENOPTIK Laser GmbH

Goeschwitzer Strasse 29 | 07745 Jena | Germany

Phone: +49 3641 65-3053 | Fax: +49 3641 65-4011

E-mail: sales-laser.lm@jenoptik.com | www.jenoptik.com/diodelasers



Fiber-Coupled Diode Lasers

JOLD-65-FC-11, cw, passively cooled, high brightness



Typical Characteristics (at 25 °C)

Optical Outputpower and Electro-Optical Efficiency

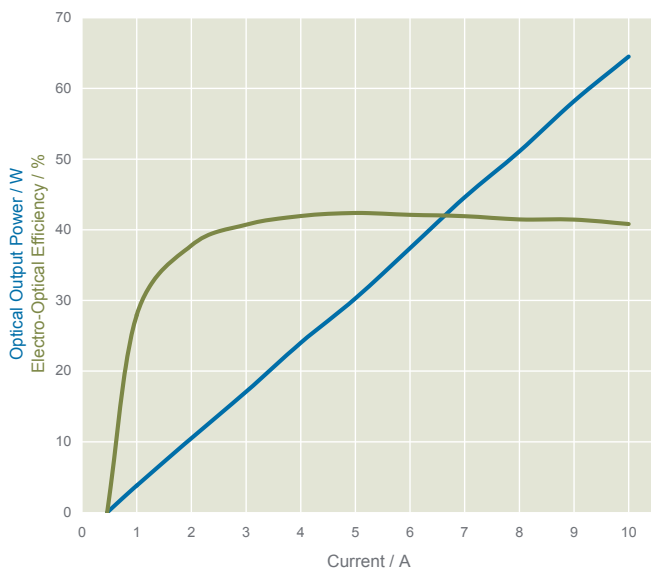

Wavelength Spectrum at 65 W

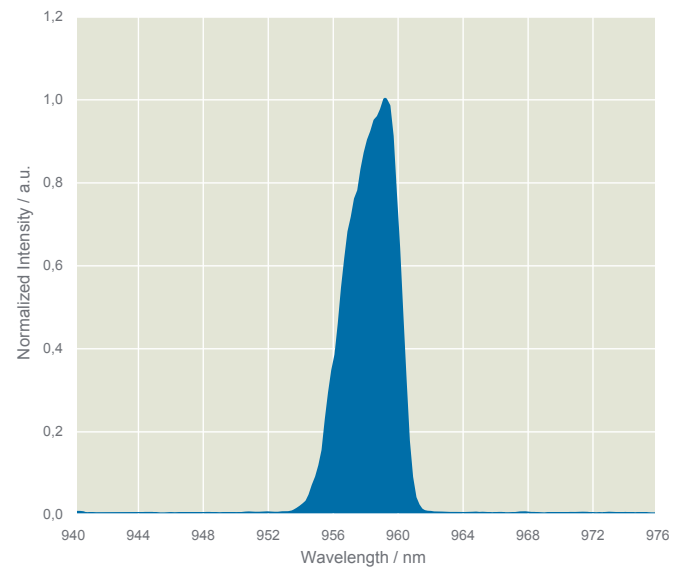

Fiber-Coupled Diode Lasers - Characteristics

JOLD-65-FG-11, cw, passively cooled, high brightness

Typical Characteristics

Center Wavelength vs. Output Power

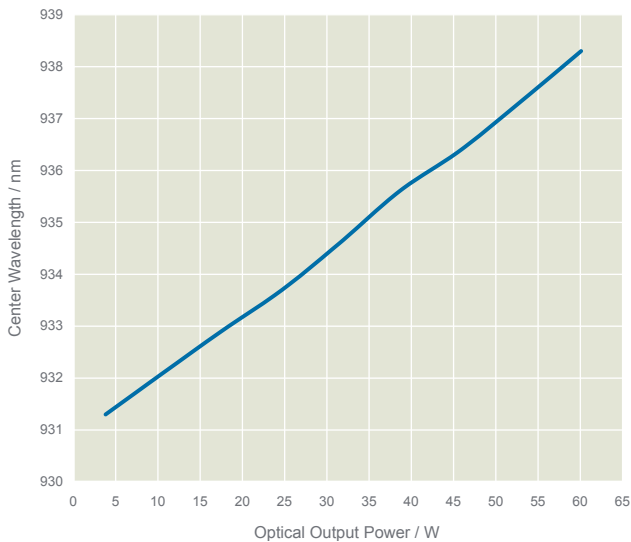

NA Distribution after Fiber at 65 W

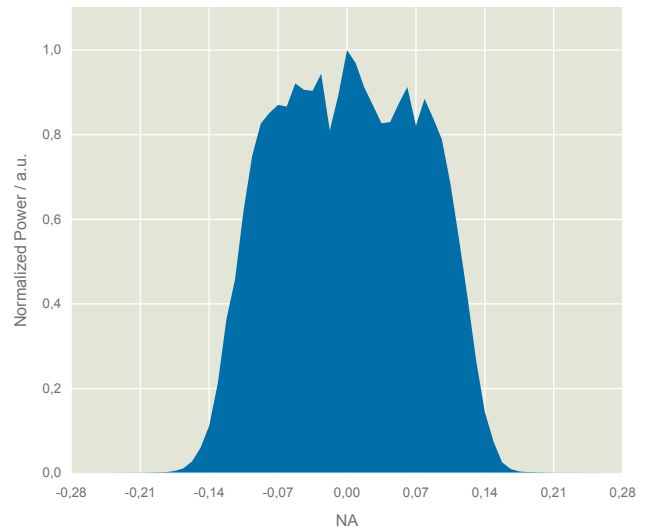

Module Lifetime - From Single Emitter Cell Tests Calculated

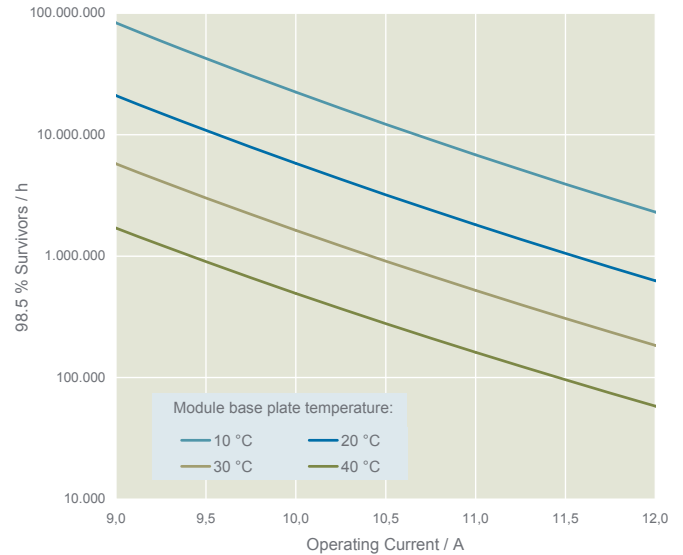
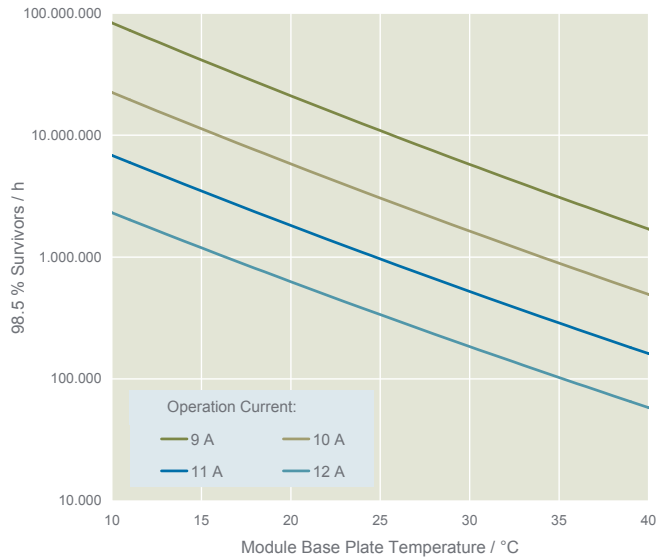

Notes:



JENOPTIK | Lasers & Material Processing

JENOPTIK Laser GmbH

Goeschitzer Strasse 29 | 07745 Jena | Germany

Phone: +49 3641 65-3053 | Fax: +49 3641 65-4011

E-mail: sales-laser.lm@jenoptik.com | www.jenoptik.com/diodelasers