

ESD precautions

semiconductor diodes

the nature of ESD

Using nanoplus lasers, correct handling of the device and electronic connections are important. Many critical parameters, including wavelength tuning, lifetime, day-to-day repeatability, threshold current and efficiency, are highly dependent on these precautions. This note gives a short introduction to Electro Static Discharge (ESD) issues and ways to avoid damage of your laser. More general information may be found e. g. in [1] and a detailed description of the causes and damages for semiconductor lasers in [2, 3]. More than 30 % of electronic failures are caused by ESD, so it is worth spending some time for finding ways to avoid ESD. The main cause of electrostatic charge on materials is the unequal sharing of surface charge when two materials are brought together or separated. But charge may also build up due to external electric fields. It is easy to generate voltages >100 V by the simple act of walking over a carpet. ESD occurs when the charged object is connected to ground or an object at a different potential, involving the transfer of electrons. In principle all objects are on different potential, unless they are on the same ground. The noticeable visible sparks are in the order of 10.000 V, but an invisible 15 V ESD may already destroy your device.

wrist straps and work areas

Bringing all items including the operator to the same ground is the only way to avoid ESD. This is as easy as wearing a wrist strap at all times when handling laser diodes, as the main cause of ESD is people. The wrist strap must be properly grounded to the same ground as the other items (tools, instruments, other material) in use. In addition, you may use ESD protective floors, shoes and foot straps [4]. Shoes that are not ESD safe should have a strap connecting the inside of the operator's socks to the outside of the shoes, as these shoes are mostly insulating. Designing an ESD protective area is the best way to protect the device.



warranty

ESD precautions when handling the device cannot be influenced by the manufacturer, in consequence nanoplus is not responsible for ESD-damaged lasers. All devices leave nanoplus in tested condition and in ESD safe environment to prevent ESD damage during transport. Before unpacking the laser, use ESD precautions. E. g. using a voltmeter for testing will destroy it immediately, so only use appropriate instruments and tools for a long lifetime of your laser.



device protected by
US patent 6.671.306
US patent 6.846.689
EU patent EP0984535

nanoplus
Nanosystems and Technologies GmbH
Oberer Kirschberg 4
D-97218 Gerbrunn

phone: +49 (0) 931 90827-0
fax: +49 (0) 931 90827-19
email: sales@nanoplus.com
internet: www.nanoplus.com

© copyright nanoplus GmbH 2012. All rights reserved.
nanoplus GmbH reserves the right to modify these specifications
at any time without notice.



[1] <http://www.esda.org/aboutesd.html>

[2] *Semiconductor laser damage due to human-body-model electrostatic discharge*, Twu, Y. et al, J. Appl. Phys. 74 (3), 1510-1520, 1993.

[3] *Human-body-model electrostatic-discharge and electrical-overstress studies of buried-heterostructure semiconductor lasers*, Huang, J. et al, IEEE Transaction on Devices and Materials Reliability, 7 (3), 453-461, 2007.

[4] Such item may be purchased from optical laboratory equipment vendors.

ESD precautions
thermal management
n+ packages

thermal management design considerations

general

Using nanoplus lasers, correct handling of the temperature control and thermal management of your system are important. Many critical parameters, including wavelength tuning, lifetime, day-to-day repeatability, threshold current and efficiency, are highly dependent on the laser temperature. A temperature stability below 10 mK is desirable for most applications. In addition, DFB laser diodes tune their wavelength with temperature, so control of it is essential and using the laser in the specified temperature range is necessary.

design suggestions

The details of the mounting are determined by considerations of how to keep the temperature of the laser as stable as possible. However, because diode lasers and associated optics can be much smaller and lighter than other types of lasers, the scale of the assembly is often quite different. The figure shows our TO5 and our Butterfly laser mount.

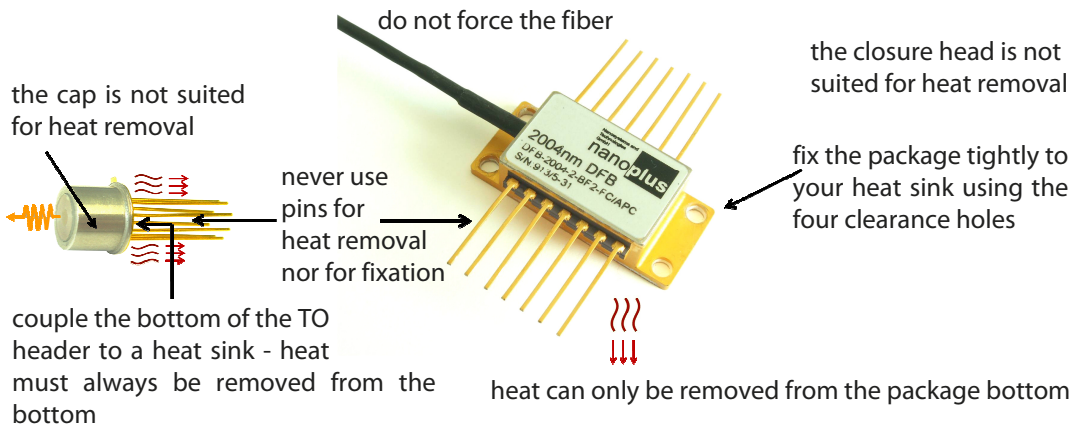

In the shown TO5 case, the laser-chip is soldered on top of a heat spreader, which is mounted to the TEC. The bottom of the TEC is attached to the TO5 base plate of the header. Because of thermal radiation and air currents, it is advisable to enclose the laser mount in some sort of container, which is also keeping dust out of the system and insulating it from vibrations. This TO5 package will not sufficiently dissipate the heat without further measures! So the heat must be removed from the bottom of the TO5 package as shown in the picture. Use thermal grease only in thin layers and consider long term behavior.

If you use a temperature controller, be sure to set its current limit below the maximum rating of the TEC module. To avoid oscillations, set the values of your PID controller to match the thermal load. Temperatures above 130 °C may damage the laser mount! Use a socket for connecting the pins to your circuit. If you want to solder a wire to the pins, use 280 °C as temperature for the soldering-iron, and hold the iron to the pins for less than 3 sec. Poor thermal management may cause high temperatures which are damaging the bonding. Ask the manufacturer of the temperature controller for further advice if you feel unsure about the electronics. A proper heat sink is available from nanoplus as accessory.

warranty

Thermal management of the device cannot be influenced by the manufacturer. In consequence, nanoplus cannot be responsible for thermally damaged lasers and any warranty is void. All devices leave nanoplus in tested condition and in proper environment to prevent damage during transport. Before unpacking the laser, consider thermal management and only use appropriate instruments for a long lifetime of your laser.



device protected by
US patent 6.671.306
US patent 6.846.689
EU patent EP0984535

nanoplus
Nanosystems and Technologies GmbH
Oberer Kirschberg 4
D-97218 Gerbrunn

phone: +49 (0) 931 90827-0
fax: +49 (0) 931 90827-19
email: sales@nanoplus.com
internet: www.nanoplus.com

© copyright nanoplus GmbH 2012. All rights reserved.
nanoplus GmbH reserves the right to modify these specifications
at any time without notice.

