

0.6 - 1.2 μm 1.2 - 1.8 μm 1.8 - 2.4 μm

1310 nm ADF LASER

Model EP1310-ADF-B



eblanaphotonics

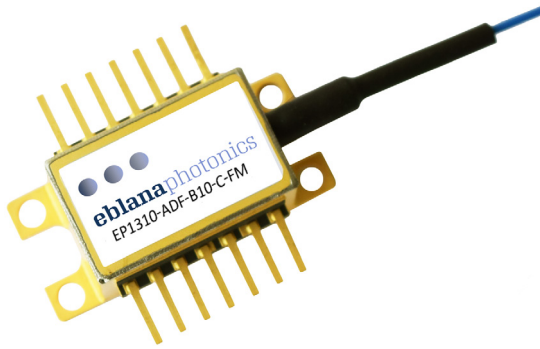

ADVANCED COMMUNICATIONS

Eblana Photonics EP1310-ADF-B laser diode is specially designed for telecoms applications such as long reach analog transmission and CATV. This cost effective laser features a highly linear output and excellent SMSR performance.

Fig. 1 Typical optical spectrum at 25 °C

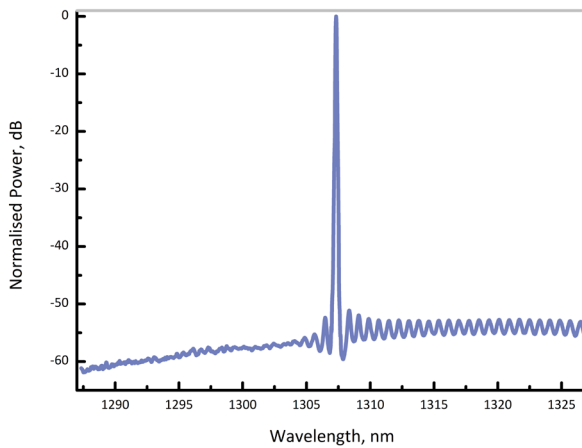
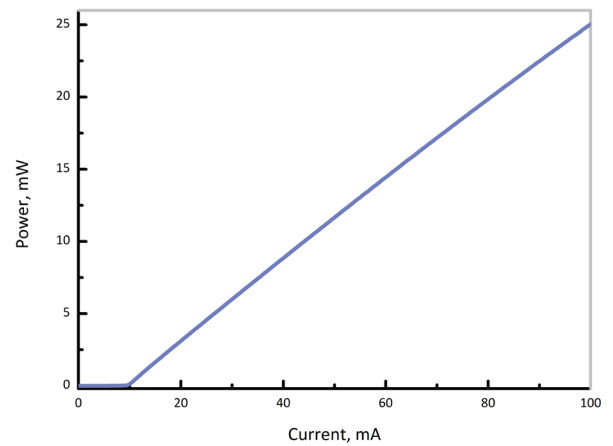

Fig. 2 Output power as a function of bias current



Electro-Optical Characteristics* ($T_{\text{SUB}} = 25\text{ }^{\circ}\text{C}$, $I_{\text{OP}} = 80\text{ mA}$)

Parameter	Symbol	Min	Typ	Max	Unit
Available Wavelength Range	λ	-	1310	-	nm
Wavelength Tolerance	λ_{spec}	$\lambda - 5$	λ	$\lambda + 5$	nm
Output Power in Fiber	P_f	17	24.5	-	mW
Slope Efficiency	SE	0.25	0.35	-	mW/mA
Threshold Current	I_{th}	-	9	12	mA
Side Mode Supression Ratio	SMSR	35	40	-	dB
Relative Intensity Noise (40-1000 MHz)	RIN	-	-	-155	dB/Hz
Temperature Tuning Coefficient	T_{λ}	-	0.10	-	nm/ $^{\circ}\text{C}$
Current Tuning Coefficient	I_{λ}	-	12	-	pm/mA
Thermistor Resistance	R_T	9.5	10	10.5	k Ω
β Coefficient (25 $^{\circ}\text{C}/85^{\circ}\text{C}$)	β	-	3892	-	K

*CW bias unless otherwise stated



Absolute Maximum Ratings

Parameter	Symbol	Min	Max	Unit
Operating Current	I_{op}	-	120	mA
Forward Voltage	V_f	-	2.5	V
TEC Current	I_{TEC}	-	1.2	A
TEC Voltage	V_{TEC}	-	3.3	V
Reverse Voltage LD	V_r	-	2	V
Reverse Voltage PD	V_{rev}	-	20	V
Case Temperature*	T_{Case}	-20	65	°C
Storage Temperature	$T_{Storage}$	-40	85	°C

*For $T_{sub} < 25\text{ °C}$, Max Case Temperature should be derated to $T_{Case,Max} = T_{sub} + 40\text{ °C}$

PACKAGING

The EP1310-ADF-B product series is offered in a 14-pin Butterfly package, shown in Figure 3 - Inquire for other packaging options. The standard package pinout is shown below in Figure 4, variations may be requested.

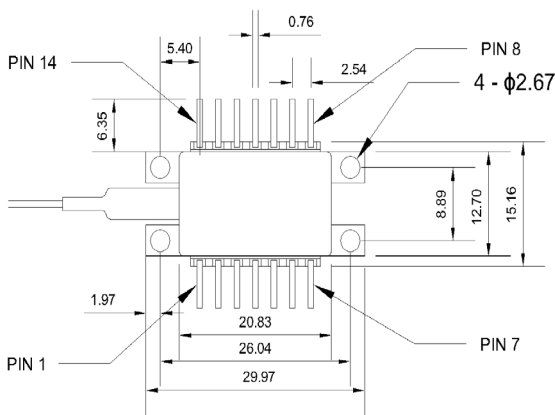

Fig. 3 Schematic of 14-pin butterfly (Dimensions in mm)

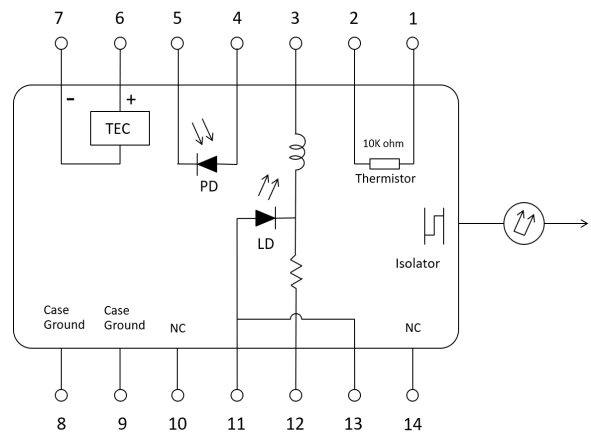
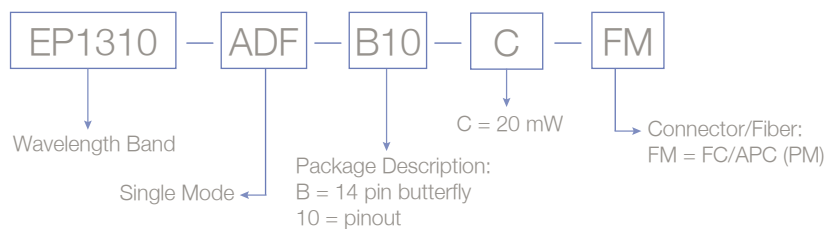

Fig. 4 Standard "Pinout 10" option

HOW TO ORDER

Construct your part number using the following example and email your order to sales@eblanaphotonics.com, or call +353 1 675 3220. Eblana's sales team are delighted to answer any questions you may have.



Laser Safety

This is a Class 3R Laser Product as defined by International Standard IEC 60825-1, Edition 3. Invisible Laser radiation is emitted from the end of the fiber or connector. Avoid direct eye exposure to the beam. Ensure appropriate Personal Protective Equipment (PPE) is worn. Laser safety is based on specifications stated in this brochure. Laser safety labels are not attached to the module due to space limitations but instead are affixed to the outside of the shipping carton. If laser is modified, classification must be re-evaluated by user.

