

DENSELIGHT SEMICONDUCTORS PTE. LTD.  
6 Changi North St. 2, S498831 SINGAPORE  
Tel: (65) 6415 4488  
Fax: (65) 6415 7988  
[www.denselight.com](http://www.denselight.com)

## **SPECIFICATIONS**

### **Ultra Narrow Linewidth 1653nm Laser In BTF Package**

### **DL-CLS081B-S1653**

DenseLight Semiconductors reserves the right to make product design or specifications changes without notice.

## **A. PRODUCT DESCRIPTION**

DenseLight **DL-CLS051B-S1653** is a cooled ultra narrow linewidth laser in BTF package with SMF pigtail emitting at 1653.5nm wavelength. It is engineered for modulation up to 622Mbps. This laser is based on an external cavity laser with built-in fiber Bragg grating, offering very stable performance of lasing wavelength, narrow spectral linewidth and excellent SMSR.

## **B. FEATURES**

- Strained InGaAsP/InP MQW gain chip coupled with built-in fiber Bragg grating
- Lasing wavelength of 1653.5nm
- Minimum 8mW CW operation
- Minimum SMSR of 45dB
- Linewidth of <200kHz
- Internal thermoelectric cooler and thermistor
- Designed for 155/622Mbps operation
- RoHS Compliance

## **C. PACKAGING**

- 14-pin BTF package with SMF-28 pigtail

## **D. APPLICATIONS**

- OTDR
- Optical measuring instrumentation
- Optical gas and chemical sensor

## E. ABSOLUTE MAXIMUM RATINGS

Parameter	Symbol	Condition	Min	Max	Unit
Reverse voltage	$V_R$			2	V
Forward current	$I_F$			120	mA
Forward voltage	$V_F$	$I_{op}$		2.5	V
Case temperature	$T_c$	$I_{op}$	0	60	°C
Laser temperature <sup>1</sup>	$T_{Laser}$	$I_{op}$	0	70	°C
Thermoelectric cooler voltage	$V_{TEC}$			3.0	V
Thermoelectric cooler current	$I_{TEC}$			1.8	A
Storage temperature	$T_{stg}$	Unbiased	-40	85	°C
Storage humidity			5	85	%RH
Electro static discharge (ESD)	$V_{ESD}$	Human body model		500	V
Lead soldering temperature	$S_{temp}$			260	°C
Lead soldering time	$S_{time}$			10	sec

<sup>1</sup>  $T_{Laser}$  is monitored by internal thermistor with external pin out.

## F. ELECTRICAL AND OPTICAL CHARACTERISTICS

( $T_{Laser} = 25\text{ °C}$ , unless otherwise noted)

Parameter	Symbol	Test Conditions	Min	Typ	Max	Unit
Optical output power	$P_O$	CW	8	–	–	mW
Threshold current	$I_{th}$	CW	–	25	35	mA
Operating current	$I_{op}$	CW, 8mW	–	–	100	mA
Operation voltage	$V_{op}$	CW, 8mW	–	–	2.0	V
Slope efficiency	$\eta$	CW, 8mW	0.06	0.1	–	mW/mA
Peak wavelength	$\lambda_p$	CW, 8mW	1652.5	1653.5	1654.5	nm
Side mode suppression ratio	SMSR	CW, 8mW	45	–	–	dB
Linewidth	$\Delta\lambda$	CW, 8mW	–	–	200	kHz
Thermistor resistance	$R_{therm}$	$T_{therm} = 25\text{ °C}$	9.5	10	10.5	k $\Omega$

<sup>2</sup> Typical linewidth is narrowed to < 10kHz when module is integrated inside DenseLight's BF-series box with high precision laser driver & temperature controller.

## G. PACKAGE

Part	Description
Package type	14-pin BTF
Fiber:	SMF-28
MFD	9 $\mu$ m
Cladding diameter	125 $\mu$ m
Coating diameter	245 $\mu$ m
Fiber pigtail length	>1m
Fiber connector	FC/APC

## H. OUTLINE DRAWINGS

### Typical Package Dimension

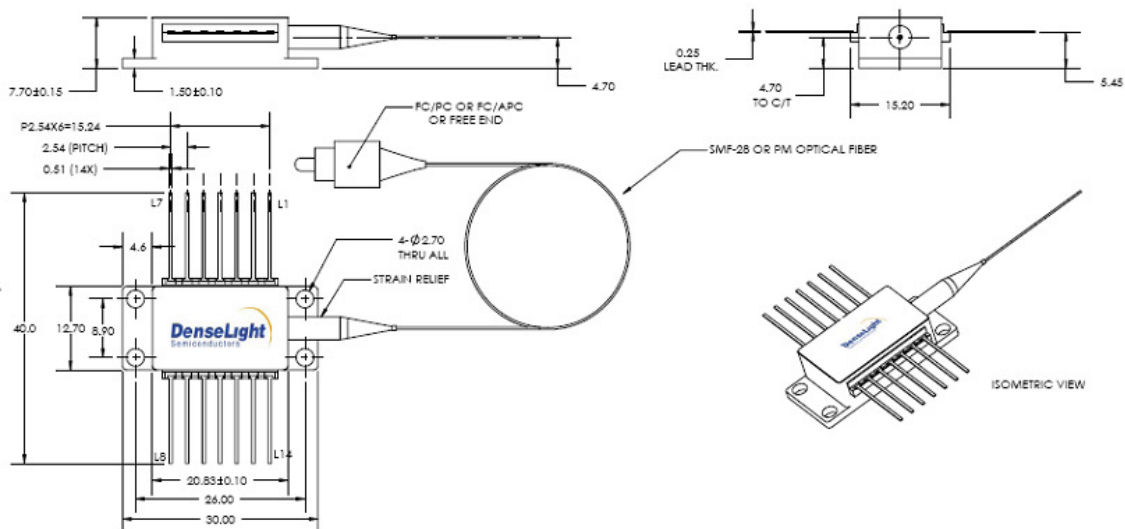

Pin Assignment	
1	TEC (+)
2	THERMISTOR
3	
4	
5	THERMISTOR
6	-
7	-
8	-
9	-
10	LD ANODE (+)
11	LD CATHODE (-)
12	-
13	CASE
14	TEC (-)

