

1550nm DM LASER

EP1550-DM-H

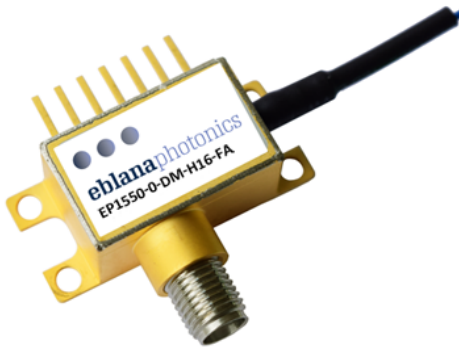

eblanaphotonics



SUPERIOR PERFORMANCE

Eblana Photonics EP1550-DM-H laser diode, available in a range from 1540nm - 1560nm, is a cost effective, highly coherent laser source, designed using Eblana's discrete-mode (DM) technology. The device features excellent SMSR and a high modulation bandwidth.

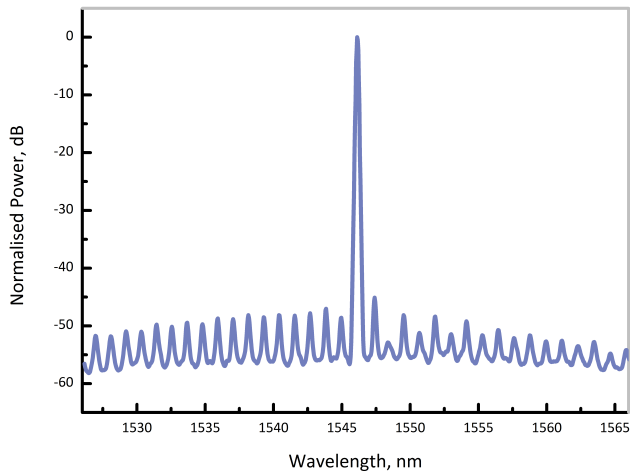

Optical Spectrum at 25°C

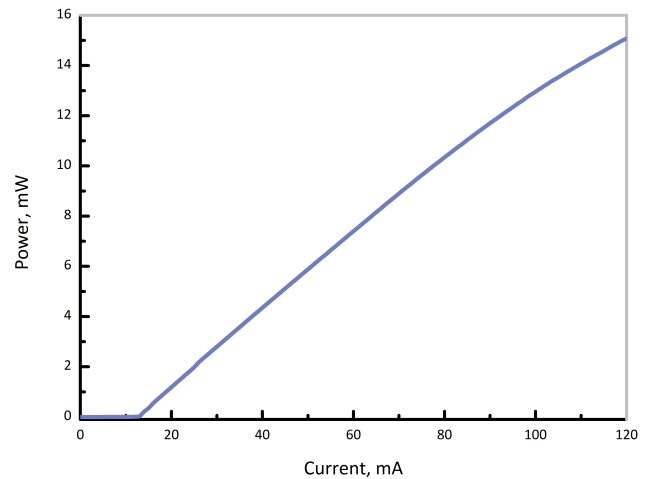

Output power vs bias current at 25°C

ELECTRO-OPTICAL CHARACTERISTICS* ($T_{SUB} = 25^{\circ} C$)

PARAMETER	SYMBOL	MIN	TYP	MAX	UNIT
Available Wavelength Range	λ	1540	1550	1560	nm
Wavelength tolerance	λ_{spec}	$\lambda - 1$	λ	$\lambda + 1$	nm
Side Mode Supression Ratio	SMSR	30	40	-	dB
Threshold Current	I_{th}	-	15	20	mA
Output Power in fiber	P_f	6	8	14	mW
3dB modulation bandwidth	f_{3dB}	-	9	-	GHz
Temperature Tuning Coefficient	T_{λ}	0.07	0.1	-	nm/°C
Current Tuning Coefficient	I_{λ}	8	12	-	pm/mA
Slope Efficiency	SE	0.1	0.12	-	mW/mA
Thermistor Resistance	R_T	9.5	10	10.5	k Ω
Thermistor Temp. Coefficient	C	-	-4.4	-	%/°C

*CW bias unless otherwise stated

©Eblana Photonics Series 1550-DM-HAA Rev 2.1



eblanaphotonics

www.eblanaphotonics.com

Sales@eblanaphotonics.com

Dublin, Ireland

ABSOLUTE MAXIMUM RATINGS

PARAMETER	SYMBOL	MIN	MAX	UNIT
Forward Current	I_f	-	120	mA
Forward Voltage	V_f	-	2	V
TEC Current	I_{TEC}	-	1.2	A
Reverse Voltage LD	V_r	-	2	V
Reverse Voltage PD	V_{rev}	-	20	V
Case Temperature*	T_{Case}	-20	65	°C
Chip Submount Temperature	T_{Sub}	0	50	°C
Storage Temperature	$T_{storage}$	-40	85	°C

*For $T_{sub} < 25^{\circ}C$, Max Case Temperature should be derated to $T_{Case,Max} = T_{sub} + 40^{\circ}C$

PACKAGING

The EP1550-DM-H product series is offered in a 7-pin package with K connector and 50 Ω RF impedance input - inquire for other packaging options. Package drawing and pinout diagram shown below.

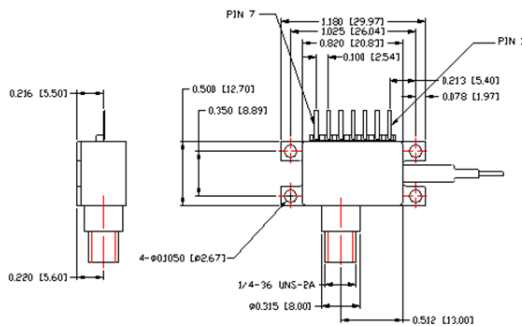

7-pin butterfly schematic

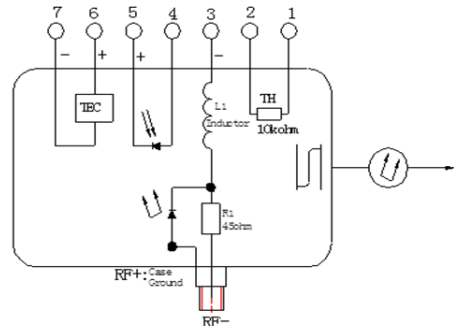

Package pinout configuration

HOW TO ORDER

Construct your part number using the following example and email your order to sales@eblanaphotonics.com, or call +353 1 675 3228.

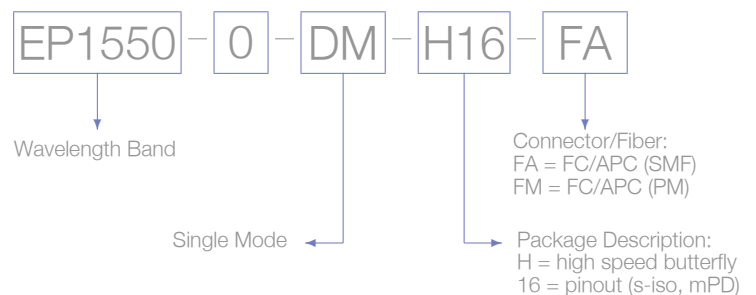

Laser Safety

This is a Class 3R Laser Product as defined by International Standard IEC 60825-1, Edition 3. Invisible Laser radiation is emitted from the end of the fiber or connector. Avoid direct eye exposure to the beam. Laser safety labels are not attached to the module due to space limitations but instead are affixed to the outside of the shipping carton.

©Eblana Photonics 2017. Eblana Photonics Reserves the right to amend this document at any time, without prior warning. ©Eblana Photonics Series 1550-DM-HAA Rev 2.1