

Model		M1470±10-15-F200/22-C5-AP		
Optical Parameters	Unit	Min	Typical	Max
Output power	W	14.5	15.0	18
Central wavelength	nm		1470	
Wavelength tolerance	nm		± 20	
Spectral width (FWHM)	nm		-	
Fiber Connector				
Fiber core diameter	µm		200	
Numerical aperture			0.22	
Connector	-		SMA905	
Electric Parameters			Typical	
Threshold current	A		0.6	
Operating current	A		8.0	9.0
Operating voltage	V		8.1	8.5
Slope efficiency	W/A		2.0	
Power conversion efficiency	%		24	
Accessories				
Thermistor	kΩ		10k@25°C	
Red aiming	-		650nm/2mW	
Other Parameters				
Operating temperature (colling plate)	°C		20 - 25	
Operating humidity	%		< 75	
Storage temperature	°C		-20 – +80	
Soldering temperature	°C		250 (10s)	

Pinout	Function
1	LD Anode
2	LD Cathode
3	Red (+5VDC)
4	Red (GND)
5	PD (N)
6	PD (P)
7	Thermistor
8	Thermistor

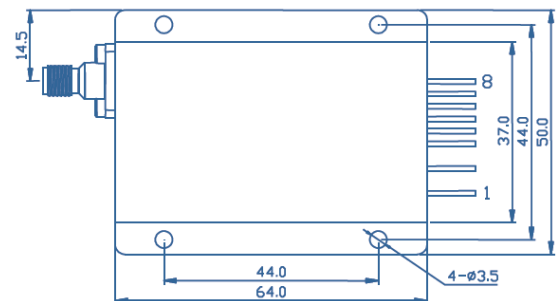

**Compliance with Regulatory Requirements:** This industrial laser is an OEM version of a laser diode. As such, it is intended only for integration into other equipment. This laser does not comply with IEC and CDRH requirements. The customer is responsible for IEC and CDRH certifications of the system that incorporates this industrial laser.

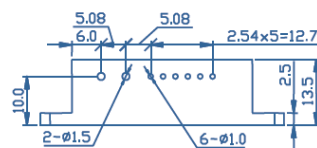