

2.5W 793nm Uncooled Multimode Laser Diode Module

BMU3-793-02-R

Features:

- High output power of min. 2.5W
- 0.22NA 105 μ m core multimode optical fiber
- Hermetically sealed 2-pin package
- Floating anode/cathode
- High reliability
- Excellent solderability
- RoHS compliant 

Applications:

- Thulium fiber laser pumping
- Medical
- Analytical

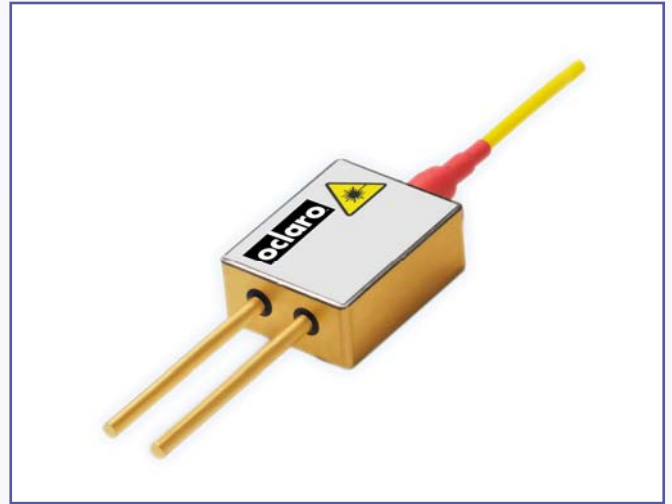

The Oclaro BMU3-793-02-R multimode laser diode module series has been designed to provide the high power and reliability required for pumping Thulium fiber lasers and for direct applications. The module includes a multimode laser diode chip with E2 front mirror passivation that prevents Catastrophic Optical Damage (COD) to the laser diode facet even at very high power levels. The coupling process allows for high output powers that are very stable with both time and temperature.

Operating Characteristics

Conditions unless otherwise stated:

Parameters at 25°C heat sink temperature and use of a thermal interface material rated for a thermal contact resistance of less than 1.3cm² K/W (0.2in² K/W). Optical fiber with 105µm core diameter and 0.22NA.

Parameter	Symbol	Typical	Unit
CW output power	P_{op}	min. 2.5	W
Center wavelength	λ_c	793 ± 3	nm
Spectral width (95% of power)	$\Delta\lambda$	3	nm
Threshold current	I_{th}	600	mA
Slope efficiency	$\eta_D = P_{op} / (I_{op} - I_{th})$	0.97	W/A
Operating current	I_{op}	3	A
Operating voltage	V_{op}	2	V
Operating temperature	T_{op}	25 ± 5	°C

Absolute Ratings

Parameter	Min	Max	Unit
ESD	-	500	V
Storage temperature	-40	85	°C
Lead soldering temperature	-	250	°C
Lead soldering time	-	10	Sec
Operating case temperature	15	60	°C
Relative humidity	5	85	%

Fiber Specification

Parameter	Min	Typ	Max	Unit
Buffer diameter	230	250	270	μm
Cladding diameter	123	125	128	μm
Core diameter	102	104	106	μm
Numeric aperture	-	0.22	-	-
Fiber length	-	1.5	-	m
Fiber bend radius	25	-	-	mm

Package Dimensions (mm)

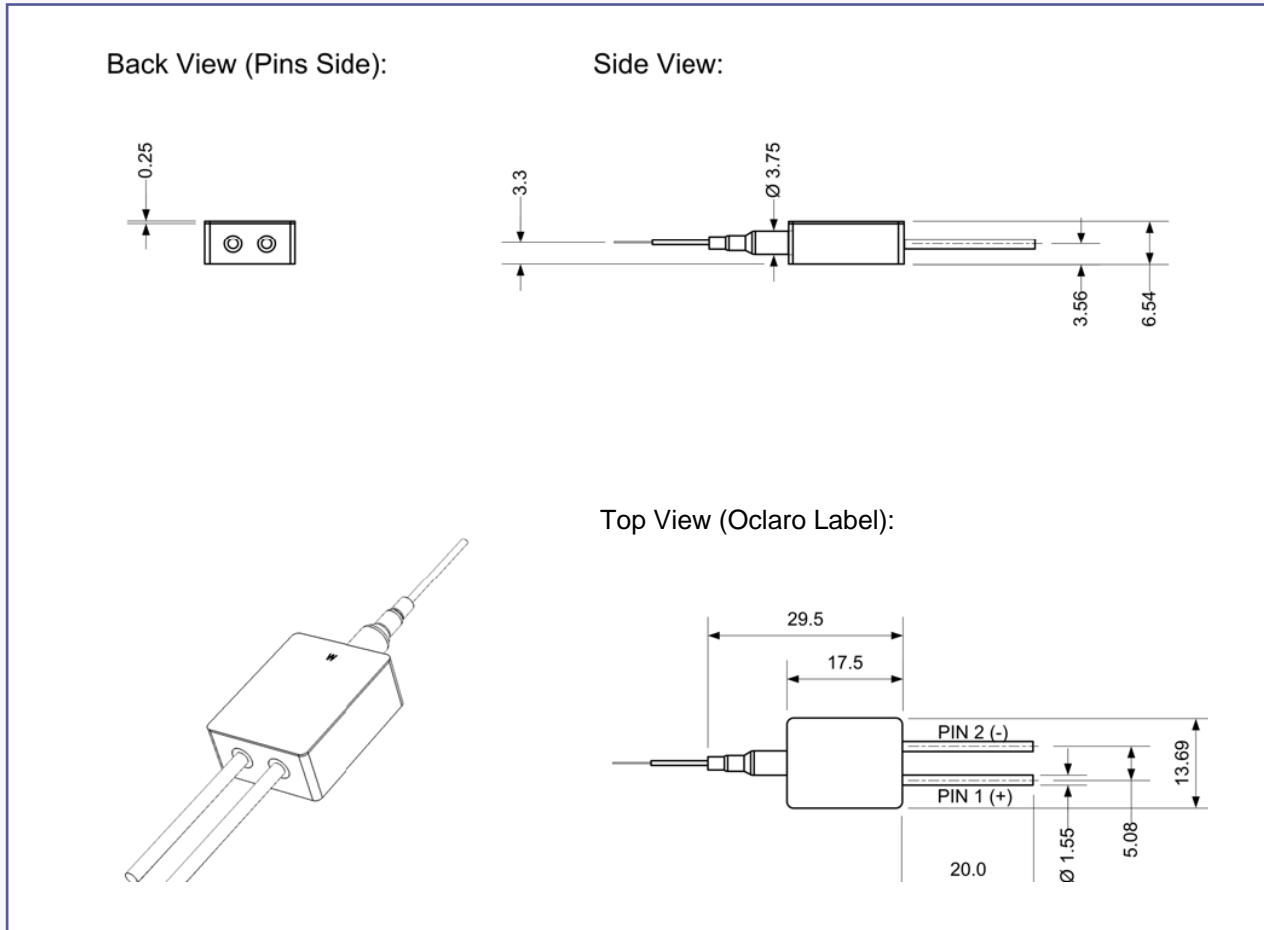

Remarks: Mounting clip is available upon request

RoHS Compliance



Oclaro is fully committed to environment protection and sustainable development and has set in place a comprehensive program for removing polluting and hazardous substances from all of its products. The relevant evidence of RoHS compliance is held as part of our controlled documentation for each of our compliant products. RoHS compliance parts are available to order, please refer to the ordering information section for further details.

Ordering Information

BMU3-793-02-R 2.5W 793 ± 3 nm Multimode Laser Diode Module with 105µm 0.22NA fiber

Contact Information

Oclaro Inc.
Worldwide Headquarters
 2584 Junction Avenue
 San Jose
 CA 95134
 USA

Tel: +1 408 383 1400
 Fax: +1 408 919 1501

www.oclaro.com
APSEurope@oclaro.com

Important Notice

Performance figures, data and any illustrative material provided in this data sheet are typical and must be specifically confirmed in writing by Oclaro before they become applicable to any particular order or contract. In accordance with the Oclaro policy of continuous improvement specifications may change without notice. The publication of information in this data sheet does not imply freedom from patent or other protective rights of Oclaro or others. Further details are available from any Oclaro sales representative.



BMU3-808-02R Rev 1.1 August 2009
 ©Oclaro 2009. Oclaro the Oclaro, Inc. logo, and all other Oclaro, Inc product names and slogans are trademarks or registered trademarks of Oclaro, Inc. in the U.S.A. or other countries. Products described in this datasheet may be covered by one or more patents in the U.S.A. and abroad. Information in this datasheet is subject to change without notice.