

EXS210005-01

EXS0830-020-10-0204131

SLED Butterfly 830nm

Revision: 1.1
Date: 01-10-2012
Confidentiality: **None**

Prepared by: Raffaele Rezzonico
(Product Support Technician)

Checked by: Chris Armistead
(Engineering Manager)

Approved by: Philippe Crépellière
(Quality Manager)

Authorized by: Marcus Duellk
(CTO)

CONTENTS

| | |
|---|----------|
| 1. SCOPE | 3 |
| 1.1 PURPOSE..... | 3 |
| 1.2 RESPONSIBILITY | 3 |
| 2. REFERENCE DOCUMENT | 3 |
| 3. ELECTRO-OPTICAL PERFORMANCE (T_{SLED} = 25°C) | 3 |
| 4. ABSOLUTE MAXIMUM RATINGS | 4 |
| 5. SCREENING | 4 |
| 6. PACKAGE DIMENSIONS [MM] | 5 |
| 7. FIBRE AND CONNECTOR | 5 |
| 8. IMPORTANT NOTES | 6 |
| 9. ORDERING INFORMATION | 6 |
| 9.1 TECHNICAL DESCRIPTION..... | 6 |
| 10. REVISION HISTORY | 7 |

1. SCOPE

1.1 PURPOSE

The purpose of this document is to specify the electro-optical performance and dimensions of superluminescent light emitting diode (SLED).

1.2 RESPONSIBILITY

EXALOS is responsible for establishing, implementing and maintaining this procedure. The Quality representative shall ensure that a timely Engineering Change Notice (ECN) is issued in accordance with EXALOS procedure for any changes.

2. REFERENCE DOCUMENT

- EXS-WI-0001 Visual Inspection Criteria SLED Chip on Submount Procedure
- MIL STD 883 C method.
- Bellcore GR-468-CORE.

3. ELECTRO-OPTICAL PERFORMANCE ($T_{SLED} = 25^{\circ}C$)

| Parameter | Symbol | Cond. | Min | Typ | Max | Unit |
|-----------------------------|-------------|---------------|-----|-----|-----|------|
| Operating Current | I_{op} | | | | 140 | mA |
| Power in SMF | P_o | $I_{op, max}$ | 7 | 10 | | mW |
| Center Wavelength | λ_c | $I_{op, max}$ | 810 | 830 | 850 | nm |
| Bandwidth FWHM | | $I_{op, max}$ | 16 | 20 | | nm |
| Spectral ripple [RB=0.05nm] | | $I_{op, max}$ | | 0.1 | 0.3 | dB |
| Monitor PD Current* | I_{MPD} | $I_{op, max}$ | 0.1 | | | mA |
| Monitor PD bias voltage | | | 0 | | -12 | V |

* Measurement conditions:

- $I_{op} = I_{op, Max}$
- Monitor PD bias voltage: 0 Volts

Input resistance of the Monitor PD current measurement circuit 10 Ohm

4. ABSOLUTE MAXIMUM RATINGS

Stresses beyond the absolute maximum ratings may cause permanent damage to the device. Exposure to absolute maximum rating conditions for extended periods may affect device reliability.

| Parameter | Symbol | Cond. | Min | Max | Unit |
|-------------------------------|----------------------------------|---------------|------|-----|------------|
| Forward current | I_F | | | 150 | mA |
| Reverse voltage | V_R | | | -2 | V |
| Forward voltage | V_F | $I_{F,max}$ | | 3.0 | V |
| Storage temperature | T_{stg} | | -40 | 85 | °C |
| Operating temperature | T_{op} | $I_{F,max}$ | -20 | 65 | °C |
| Storage humidity | $<30^{\circ}C$ $>30^{\circ}C$ | | 5 | 95 | % r.h. |
| | | | | 85 | % r.h. |
| Thermoelectric cooler voltage | V_{tec} | ** | | 4.0 | V |
| Thermoelectric cooler current | I_{tec} | ** | | 1.8 | A |
| Thermistor Resistance | R_{th} | $25^{\circ}C$ | 10 | | K Ω |
| Thermistor constant | B | | 3892 | | K |
| Lead soldering temperature | | | | 260 | °C |
| Lead soldering duration | | | | 10 | s |
| ESD | | human b.m | | 500 | V |

** Performance values with hot side temperatures $50^{\circ}C$

5. SCREENING

The produced 830nm SLED Module is required to meet all operating conditions specified in Table 3, Electro-Optical Performance Specifications after being subjected to the following screening tests.

| Test Item | Test Conditions | Reference |
|---------------------|---|---|
| Seal | Fine: Condition A1 Gross: Condition C | MIL-STD-883, Method 1014 Temperature max $85^{\circ}C$ |
| Temperature Cycling | $-40^{\circ}C$ to $+85^{\circ}C$, ramp rate $\geq 5^{\circ}C/min$ 10 cycles | MIL-STD-883, Method 1010 |

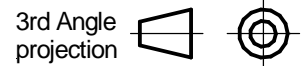

6. PACKAGE DIMENSIONS [mm]

Tolerances : .X ± 0.25 mm
.XX ± 0.05 mm

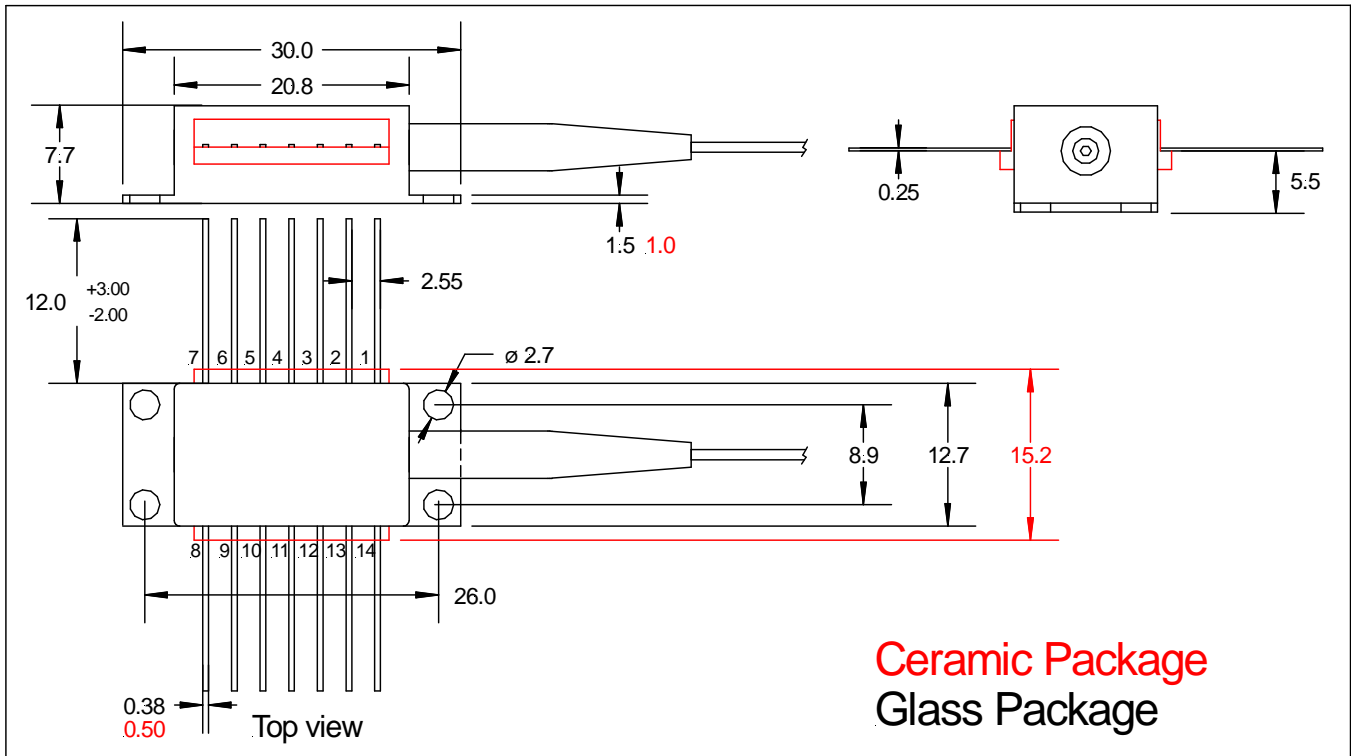

| Butterfly Package | | | |
|-------------------|-----------------------|-----|------------------|
| Pin | Function | Pin | Function |
| 1 | TEC (+) | 8 | NC |
| 2 | THERMISTOR | 9 | NC |
| 3 | MONITOR DIODE ANODE | 10 | SLED ANODE (+) |
| 4 | MONITOR DIODE CATHODE | 11 | SLED CATHODE (-) |
| 5 | THERMISTOR | 12 | NC |
| 6 | NC | 13 | CASE GROUND |
| 7 | NC | 14 | TEC (-) |

7. FIBRE AND CONNECTOR

| Part | Description |
|------------------------------|---------------------------|
| SM Fibre | SM 5/125 Corning HI780 |
| Loose tube secondary coating | 900 µm |
| Fiber pigtail length [min] | 1 m |
| Optical connector | FC/APC Narrow Key (2.0mm) |

8. IMPORTANT NOTES

1. Avoid electrostatic discharges, which may destroy the SLED.
2. Never use the bare die without heat sinking.
3. Adequate eye protection against laser radiation should be used while handling and operating the module.
4. EXALOS declines any responsibility if the device is used in applications where human life may be endangered.
5. Back reflections may influence the output power and spectral characteristics of the SLED. The use of optical isolators and/or angled connectors is recommended. Back reflections of less than -30dB are recommended.

9. ORDERING INFORMATION

Please use the following **part number** to order product from EXALOS:

E X S 2 1 0 0 0 5 - **0 1**

9.1 TECHNICAL DESCRIPTION

