

Description

The VPSL-0635-015-x-9-B is a 0.63 μm band, AlGaInP index-guided, multi-quantum well (MQW) laser diode with an integrated, internal, beam correcting optic. It is suitable as a light source for laser levelers and optical equipment for measurement. Hermetic sealing of the package assures high reliability.

Features

- Visible light output
- 15mW optical power
- Built-in monitor photodiode
- Circular, diverging beam, NA approximately 0.11
- Diffraction limited wavefront, aberration equal or better than $\lambda/4$ peak to valley
- Standard 9mm form factor

Absolute Maximum Ratings (T_C =case temperature= 25°C) *

Item	Symbol	Min	Max	Unit
Optical output power	P_O	-	15	mW
LD reverse voltage	V_R (LD)	-	2	V
PD reverse voltage	V_R (PD)	-	30	V
Operating temperature	T_{opr}	-10	+50	$^\circ\text{C}$
Storage temperature	T_{stg}	-40	+85	$^\circ\text{C}$

Optical and Electrical Characteristics (T_C =case temperature= 25°C) *

Item	Symbol	Min	Typ	Max	Unit	Test Conditions
Threshold current	I_{th}	20	55	75	mA	
Operating current	I_{op}	-	85	105	mA	$P_O=15\text{mW}$
Operating voltage	V_{op}	-	-	2.7	V	$P_O=15\text{mW}$
Optical output power	P_O	-	-	15	mW	Kink free
Slope efficiency	η	0.3	-	0.7	mW/mA	$P_O=15\text{mW}$
Lasing wavelength	λ_p	625	635	642	nm	$P_O=15\text{mW}$
Circularity	ϕ		-	1.2:1.0	Ratio	$P_O=15\text{mW}$
Beam divergence	θ	5	8	11	Deg	$P_O=15\text{mW}$, FWHM
Off axis angle	$\Delta\theta$	-	-	± 3	Deg	
Monitor current	I_S	0.07	0.20	0.45	mA	$P_O=15\text{mW}$, $V_r(pd)=5\text{V}$
Astigmatism	A_S	-	-	0.25	Waves	

- *Specifications are subject to change without notice. Each purchased CircuLaser is provided with test data. Please refer to this data before using the CircuLaser.*
- *This laser was previously known as the PS028-00 Circulaser.*

CircuLaser - Package Detail, Mechanical & Electrical – VPSL-0635-015-x-9-B

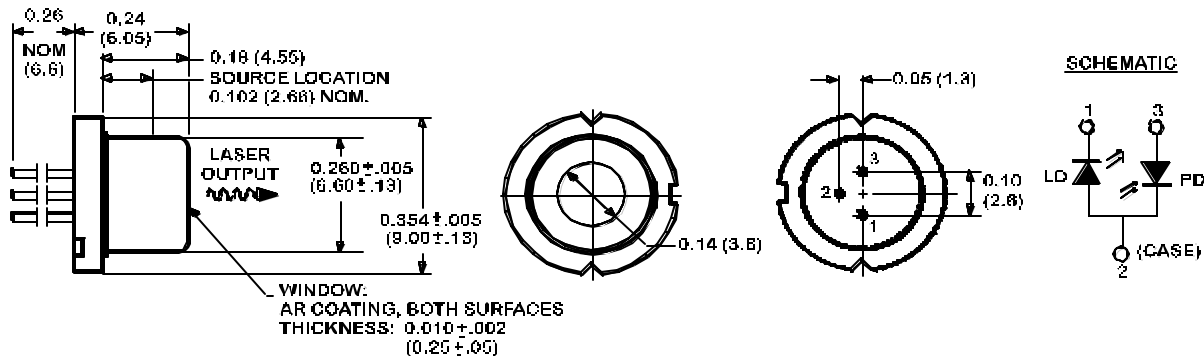

Handling Care and Precautions for Use of CircuLaser Diodes

1. Absolute Maximum Ratings

Do not exceed, *even momentarily*, the maximum ratings (see page 1, table). When a CircuLaser diode is driven in excess of its maximum ratings, it can cause at minimum a considerable reduction in reliability, and potentially instantaneous failure.

- CircuLaser diodes may be damaged by surge currents generated at power on-off operation. Check on the transient characteristics of the power supply to make sure that such surges do not exceed the maximum ratings.
- The maximum ratings are specified for a case temperature of 25°C. Designs should be made to work well within this temperature range. As the case temperature goes up, power dissipation as well as maximum light output power is reduced.

2. Soldering Conditions

Maximum solder-tip temperature is 260°C and soldering time must be within 3.0 seconds. A minimum solder clearance of 1.6mm should be maintained from the root of the lead.

3. Prevention of Breakdown due to Static Electricity

CircuLaser diodes may be adversely affected by static electricity and surge currents and, consequently, cause breakdown of the diode and reduction of reliability unless the following precautions are taken:

- Power supplies, installation and measuring equipment should be grounded. A noise filter or noise-cut transformer should be provided on any power supply inputs.
- Anyone working with a CircuLaser diode should be grounded through high resistance (500 K Ohm - 1M Ohm) by means of a ground strap and wrist band (for example).
- Soldering irons should be grounded to protect laser diodes from voltage leaks.
- During operation of the CircuLaser diode, working clothes, hats, and shoes should be static-protected. Cotton-based clothing is preferred.
- Any container for carriage and storage should be static-protected.
- Avoid using laser diodes in an environment where high frequency surge currents may be generated by an inductive electric field (such as a fluorescent lamp). These fields can also cause breakdown or deterioration of the laser diode.

4. Package Handling

- The laser diode package should not be cut off, reworked, or deformed. Do not hold the cap of the CircuLaser diode tightly, otherwise it may induce cracks or damage to the window glass.
- Do not touch the surface of the window glass. Any scratch or contamination may result in reduction of optical characteristics.
- Remove small contaminates on the surface softly using a cotton tip stick with a small amount of methyl alcohol.

5. Safety

The output light from laser diodes is harmful to a human body even if it is invisible. Avoid looking at the output light of a CircuLaser diode directly, or even indirectly through a lens during operation. Observance of operation should be through an infrared TV camera or related equipment. Refer to IEC 825-1 and 21 CFR 1040.10-1040.11 as a radiation safety standard for laser products.

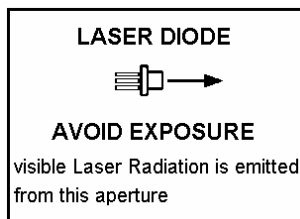

BSR154 8/14/2006