

1.5 μm Integrated Laser Diode Pump Module

The Princeton Lightwave Integrated Laser Diode Pump Module provides collimated high-brightness optical pumping at 1470 nm or 1530 nm. This product employs precision beam combining of multimode single emitters based on PLI's industry-leading InGaAs/InP laser diode device technology. The use of a module design based on single emitters enables high brightness in both CW and quasi-CW operation as well as excellent beam quality and high reliability. The module's architecture also provides significant advantages related to the thermal management of pump sources, and the sealed chassis ensures stable operation of these sources in harsh environments.

Features

- “Eye-safe” operating wavelengths
- Available with 1470 nm or 1530 nm output
- High brightness
- High power in CW (30 W) and quasi-CW (50 W) operation
- Excellent beam quality
- Available with ultra-narrow spectral width (< 1 nm)
- Combined single emitter technology
- Sealed chassis design for harsh environment

Applications

- Solid-state laser pumping
- Eye-safe SWIR illuminators
- Material processing
- Scientific equipment



Inquire for additional features:

- Custom wavelengths in 1300 – 1900 nm range
- Ultra-narrow spectral width of < 1 nm
- Fiber-coupled output

Specifications subject to change without notice

Princeton Lightwave high power laser products and associated technical data may be subject to the controls of the US Export Administration Regulations (EAR).

2555 US Route 130 S.
Cranbury, NJ 08540
Tel: 609-495-2600
<http://www.princetonlightwave.com>
© 2011, Princeton Lightwave, Inc.
Rev. 1.0

Part No. PML-XXXXX: 1.5 μm Integrated Laser Diode Pump Module

TYPICAL SPECIFICATIONS

Operating Conditions: 15 °C operating temperature, 50 Hz repetition rate, QCW pumping 3.5 ms (unless noted otherwise)

Parameter	Symbol	Conditions	Wavelength		Units
			1470 nm	1530 nm	
Output Power, CW	$P_{op,cw}$	CW at T_{op}	35	30	W
Output Power, QCW	$P_{op,qcw}$	QCW at 5ms / 20Hz	60	50	W
Spectral width [1]	$\Delta\lambda$	at $P_{op,cw}$	10	12	nm
Beam parameters	BP	at $P_{op,cw}$	12	12	mm•mrad
Operating temperature	T_{op}	at baseplate	20	20	°C
Heat Load	P_{dis}	at $P_{op,cw}$	<120	<120	W

Notes: [1] available with spectral width <1 nm

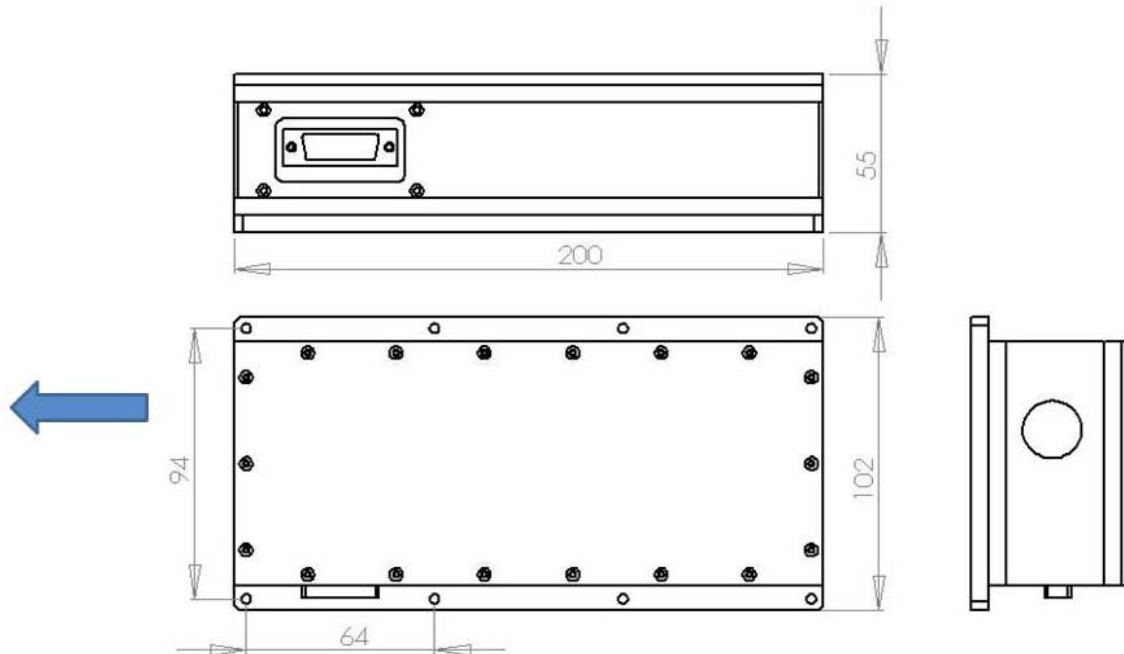

(All dimensions in mm)

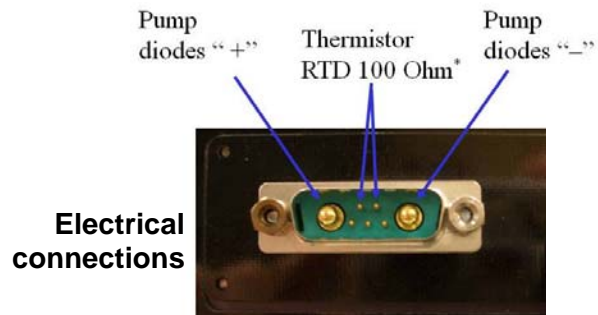

Specifications subject to change without notice

Princeton Lightwave high power laser products and associated technical data may be subject to the controls of the US Export Administration Regulations (EAR).

2555 US Route 130 S.
 Cranbury, NJ 08540
 Tel: 609-495-2600
<http://www.princetonlightwave.com>
 © 2011, Princeton Lightwave, Inc.
 Rev. 1.0