

## DWDM CW DFB Laser Module

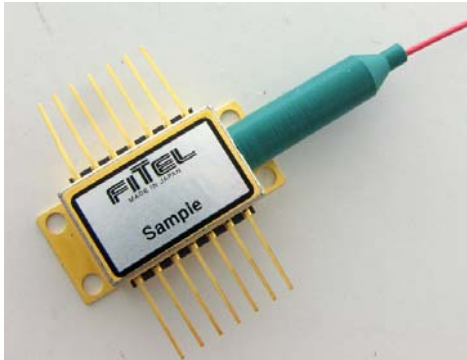

### Applications

- OC-192/STM-64 DWDM Transmission Systems

### Descriptions

- FRL15DCWx series of DFB laser module is designed for long haul DWDM applications with external intensity modulator.
- The polarization maintaining fiber pigtail enables to directly connect a modulator without polarization control. The polarization state of output laser beam is maintained to a consistent orientation.
- A strained multi-quantum well DFB laser diode chip is integrated with optical isolator, thermo-electric cooler (TEC), thermistor and power monitor photodiode in an industry standard hermetically sealed 14 pin butterfly package.
- This laser module complies with telecom requirements described in Telcordia™ GR-468 and is manufactured in an ISO™9001 certified production line.

### Features

- High optical output power up to 40mW
- High side mode suppression ratio(SMSR)
- Selected wavelength according to ITU-T Grid, C and L-band available
- 50GHz spacing available
- Narrow linewidth available
- RoHS compliant package

### Absolute Maximum Ratings

| Parameters                 | Sym.             | Min. | Max. | Unit |
|----------------------------|------------------|------|------|------|
| Storage Temperature        | T <sub>stg</sub> | -40  | 85   | °C   |
| Operating Case Temperature | T <sub>c</sub>   | -5   | 70   | °C   |
| LD Reverse Voltage         | V <sub>rLD</sub> | -    | 2    | V    |
| LD Forward Current         | I <sub>fLD</sub> | -    | 350  | mA   |
| LD Operating Temperature   | T <sub>LD</sub>  | 20   | 35   | °C   |
| Relative Humidity          | RH               | 0    | 85   | %    |
| Fiber Bend Radius          | -                | 30   | -    | mm   |
| Fiber Axial Pull Force     | -                | -    | 9.8  | N    |

| Parameters                         | Sym.             | Min. | Max. | Unit |
|------------------------------------|------------------|------|------|------|
| PD Reverse Voltage                 | V <sub>rPD</sub> | -    | 20   | V    |
| PD Forward Current                 | I <sub>fPD</sub> | -    | 5    | mA   |
| TEC Current                        | I <sub>tec</sub> | -    | 1.6  | A    |
| TEC Voltage                        | V <sub>tec</sub> | -    | 2.6  | V    |
| Lead Soldering                     | -                | -    | 260  | °C   |
| Lead Soldering Duration            | -                | -    | 10   | sec  |
| Torque Force<br>(Flatness : <20μm) | -                | -    | 0.1  | Nm   |

## Specifications (T<sub>c</sub>=25°C, BOL\*<sup>1</sup> unless otherwise specified)

| Parameters                    | Symbol           | Min.                  | Typ.             | Max.                  | Unit  | Conditions   |
|-------------------------------|------------------|-----------------------|------------------|-----------------------|-------|--|
| Optical Output Power          |                  |                       |                  |                       |       |  |
| FRL15DCWA                     | Pf               | 10                    | -                | -                     | mW    | CW   |
| FRL15DCWB                     |                  | 20                    | -                | -                     |       |  |
| FRL15DCWD                     |                  | 40                    | -                | -                     |       |  |
| LD Forward Current            |                  |                       |                  |                       |       |  |
| FRL15DCWA                     | If               | -                     | -                | 80                    | mA    | Rated power, CW  |
| FRL15DCWB                     |                  | -                     | -                | 150                   |       |  |
| FRL15DCWD                     |                  | -                     | -                | 300                   |       |  |
| LD Operating Temperature      | T <sub>LD</sub>  | 20                    | -                | 35                    | °C    | Rated power, CW  |
| LD Forward Voltage            |                  |                       |                  |                       |       |  |
| FRL15DCWA, B                  | Vf               | -                     | -                | 1.8                   | V     | Rated power, CW  |
| FRL15DCWD                     |                  | -                     | -                | 2.5                   |       |  |
| Threshold Current             | I <sub>th</sub>  | -                     | 15               | 40                    | mA    |  |
| Wavelength                    | λ                | λ <sub>ITU</sub> -0.1 | λ <sub>ITU</sub> | λ <sub>ITU</sub> +0.1 | nm    | Rated power, CW<br>See Table.1   |
| Linewidth (-3dB fullwidth)    |                  |                       |                  |                       |       |  |
| Standard                      | Δv               | -                     | -                | 10                    | MHz   | Rated Power, CW<br>Option C is available only<br>for FRL15DCWD.            |
| Option A                      |                  | -                     | -                | 5                     |       |  |
| Option B                      |                  | -                     | -                | 2                     |       |  |
| Option C                      |                  | -                     | -                | 1                     |       |  |
| Side Mode Suppression Ratio   | SMSR             | 35                    | 45               | -                     | dB    | Rated power, CW  |
| Optical Isolation             | Iso              | 30                    | -                | -                     | dB    |  |
| Relative Intensity Noise      |                  |                       |                  |                       |       |  |
| FRL15DCWA                     | RIN              | -                     | -                | -133                  | dB/Hz | Rated power, CW<br>O <sub>pRL</sub> <-25dB* <sup>2</sup><br>100MHz<f<10GHz |
| FRL15DCWB                     |                  | -                     | -                | -138                  |       |  |
| FRL15DCWD                     |                  | -                     | -                | -140                  |       |  |
| Monitor Current               |                  |                       |                  |                       |       |  |
| FRL15DCWA                     | Im               | 0.05                  | -                | 1                     | mA    | Rated power, CW<br>V <sub>rPD</sub> =5V                                    |
| FRL15DCWB                     |                  | 0.1                   | -                | 2                     |       |  |
| FRL15DCWD                     |                  | 0.15                  | -                | 3                     |       |  |
| Monitor Dark Current          | I <sub>d</sub>   | -                     | -                | 100                   | nA    | V <sub>rPD</sub> =5V   |
| Tracking Error                | TE               | -0.5                  | -                | 0.5                   | dB    | I <sub>m</sub> =constant, T <sub>c</sub> =-5 to 70°C                       |
| TEC Current                   | I <sub>tec</sub> | -                     | -                | 1.2                   | A     | T <sub>c</sub> =70°C, Rated power, CW                                      |
| TEC Voltage                   | V <sub>tec</sub> | -                     | -                | 2.4                   | V     | T <sub>c</sub> =70°C, Rated power, CW                                      |
| Thermistor B constant         | B                | -                     | 3900             | -                     | K     |  |
| Thermistor Resistance         | R                | 9.5                   | -                | 10.5                  | kΩ    | T <sub>LD</sub> =25°C  |
| Polarization Extinction Ratio | Er               | 20                    | -                | -                     | dB    | Rated power, CW  |

\*<sup>1</sup> BOL : Beginning of Life\*<sup>2</sup> O<sub>pRL</sub> : Optical Return Loss

Table 1

| $\lambda_{ITU}$ [nm] | ITU Freq. [THz] | Wavelength code | $\lambda_{ITU}$ [nm] | ITU Freq. [THz] | Wavelength code | $\lambda_{ITU}$ [nm] | ITU Freq. [THz] | Wavelength code |
|----------------------|-----------------|-----------------|----------------------|-----------------|-----------------|----------------------|-----------------|-----------------|
| 1529.55              | 196.00          | 19600           | 1556.55              | 192.60          | 19260           | 1584.53              | 189.20          | 18920           |
| 1530.33              | 195.90          | 19590           | 1557.36              | 192.50          | 19250           | 1585.36              | 189.10          | 18910           |
| 1531.12              | 195.80          | 19580           | 1558.17              | 192.40          | 19240           | 1586.20              | 189.00          | 18900           |
| 1531.90              | 195.70          | 19570           | 1558.98              | 192.30          | 19230           | 1587.04              | 188.90          | 18890           |
| 1532.68              | 195.60          | 19560           | 1559.79              | 192.20          | 19220           | 1587.88              | 188.80          | 18880           |
| 1533.47              | 195.50          | 19550           | 1560.61              | 192.10          | 19210           | 1588.73              | 188.70          | 18870           |
| 1534.25              | 195.40          | 19540           | 1561.42              | 192.00          | 19200           | 1589.57              | 188.60          | 18860           |
| 1535.04              | 195.30          | 19530           | 1562.23              | 191.90          | 19190           | 1590.41              | 188.50          | 18850           |
| 1535.82              | 195.20          | 19520           | 1563.05              | 191.80          | 19180           | 1591.26              | 188.40          | 18840           |
| 1536.61              | 195.10          | 19510           | 1563.86              | 191.70          | 19170           | 1592.10              | 188.30          | 18830           |
| 1537.40              | 195.00          | 19500           | 1564.68              | 191.60          | 19160           | 1592.95              | 188.20          | 18820           |
| 1538.19              | 194.90          | 19490           | 1565.50              | 191.50          | 19150           | 1593.79              | 188.10          | 18810           |
| 1538.98              | 194.80          | 19480           | 1566.31              | 191.40          | 19140           | 1594.64              | 188.00          | 18800           |
| 1539.77              | 194.70          | 19470           | 1567.13              | 191.30          | 19130           | 1595.49              | 187.90          | 18790           |
| 1540.56              | 194.60          | 19460           | 1567.95              | 191.20          | 19120           | 1596.34              | 187.80          | 18780           |
| 1541.35              | 194.50          | 19450           | 1568.77              | 191.10          | 19110           | 1597.19              | 187.70          | 18770           |
| 1542.14              | 194.40          | 19440           | 1569.59              | 191.00          | 19100           | 1598.04              | 187.60          | 18760           |
| 1542.94              | 194.30          | 19430           | 1570.42              | 190.90          | 19090           | 1598.89              | 187.50          | 18750           |
| 1543.73              | 194.20          | 19420           | 1571.24              | 190.80          | 19080           | 1599.75              | 187.40          | 18740           |
| 1544.53              | 194.10          | 19410           | 1572.06              | 190.70          | 19070           | 1600.60              | 187.30          | 18730           |
| 1545.32              | 194.00          | 19400           | 1572.89              | 190.60          | 19060           | 1601.46              | 187.20          | 18720           |
| 1546.12              | 193.90          | 19390           | 1573.71              | 190.50          | 19050           | 1602.31              | 187.10          | 18710           |
| 1546.92              | 193.80          | 19380           | 1574.54              | 190.40          | 19040           | 1603.17              | 187.00          | 18700           |
| 1547.72              | 193.70          | 19370           | 1575.37              | 190.30          | 19030           | 1604.03              | 186.90          | 18690           |
| 1548.51              | 193.60          | 19360           | 1576.20              | 190.20          | 19020           | 1604.88              | 186.80          | 18680           |
| 1549.32              | 193.50          | 19350           | 1577.03              | 190.10          | 19010           | 1605.74              | 186.70          | 18670           |
| 1550.12              | 193.40          | 19340           | 1577.86              | 190.00          | 19000           | 1606.60              | 186.60          | 18660           |
| 1550.92              | 193.30          | 19330           | 1578.69              | 189.90          | 18990           | 1607.47              | 186.50          | 18650           |
| 1551.72              | 193.20          | 19320           | 1579.52              | 189.80          | 18980           | 1608.33              | 186.40          | 18640           |
| 1552.52              | 193.10          | 19310           | 1580.35              | 189.70          | 18970           | 1609.19              | 186.30          | 18630           |
| 1553.33              | 193.00          | 19300           | 1581.18              | 189.60          | 18960           | 1610.06              | 186.20          | 18620           |
| 1554.13              | 192.90          | 19290           | 1582.02              | 189.50          | 18950           | 1610.92              | 186.10          | 18610           |
| 1554.94              | 192.80          | 19280           | 1582.85              | 189.40          | 18940           | 1611.79              | 186.00          | 18600           |
| 1555.75              | 192.70          | 19270           | 1583.69              | 189.30          | 18930           |                      |                 |                 |

Wavelength values are referenced to vacuum.

50GHz spacing is also available.

Other ITU wavelengths may be available. Please ask to the regional contacts.

Wavelength ( $\lambda$ ) and ITU frequency (f) have a relationship of  $\lambda[\text{nm}] = 299792458 / f [\text{THz}] / 1000$ .

FITEL wavelength code is expressed as a 5-digit integer rounded from  $100 \times f [\text{THz}]$ .

## Dimensions and Pin Assignments

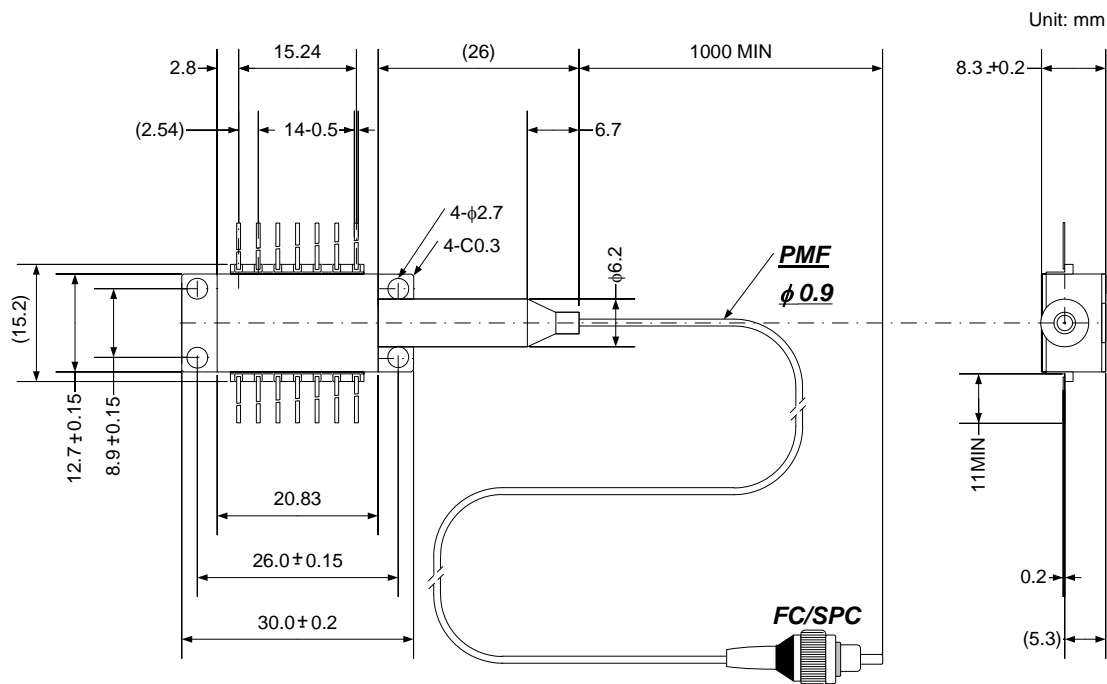

### LD Anode Ground

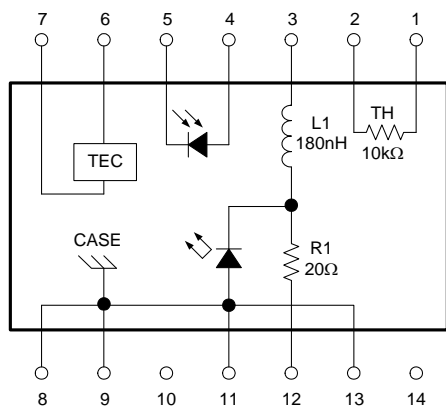

| PIN No. | Function           | PIN No. | Function                 |
|---------|--------------------|---------|--------------------------|
| 1       | Thermistor         | 8       | Case Ground              |
| 2       | Thermistor         | 9       | Case Ground              |
| 3       | LD Cathode(-)      | 10      | No Connect               |
| 4       | Monitor Anode(-)   | 11      | LD Anode(+), Case Ground |
| 5       | Monitor Cathode(+) | 12      | LD Cathode(RF)           |
| 6       | TEC(+)             | 13      | LD Anode(+), Case Ground |
| 7       | TEC(-)             | 14      | No Connect               |

### LD Anode Float

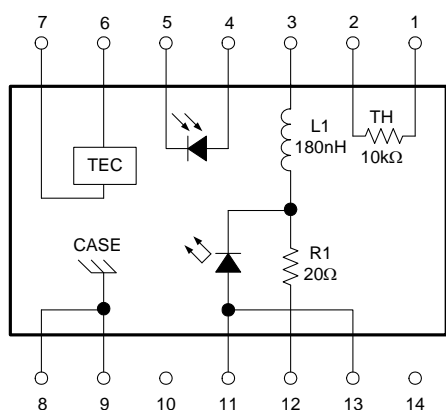

| PIN No. | Function           | PIN No. | Function       |
|---------|--------------------|---------|----------------|
| 1       | Thermistor         | 8       | Case Ground    |
| 2       | Thermistor         | 9       | Case Ground    |
| 3       | LD Cathode(-)      | 10      | No Connect     |
| 4       | Monitor Anode(-)   | 11      | LD Anode(+)    |
| 5       | Monitor Cathode(+) | 12      | LD Cathode(RF) |
| 6       | TEC(+)             | 13      | LD Anode(+)    |
| 7       | TEC(-)             | 14      | No Connect     |

## Optical Fiber Pigtail Specifications

| Parameters           | Specification   | Unit |
|----------------------|---|------|
| Fiber Type           | Polarization maintaining(PANDA) fiber<br>Frame retardant Hytel™ coating(φ0.9mm) | -    |
| Nominal Fiber Length | Min.1,000   | mm   |
| Connector Type       | FC/SPC Connector  | -    |
| Polarization Axis    | Slow Axis   | -    |

## Ordering Information

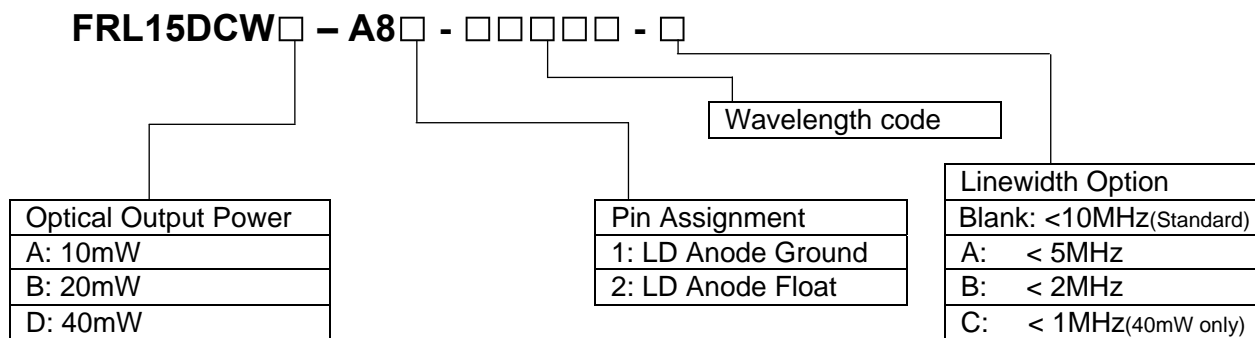

## Safety Information

This product complies with 21 CFR 1040.10 and 1040.11, Class 3b laser product. Invisible laser radiation is emitted from the end of the fiber or connector. Avoid direct exposure to the beam.

Telcordia is a trademark of Telcordia Technologies, Inc.  
ISO is a trademark of The International Organization for Standardization.  
Hytel is a trademark of DuPont.



Furukawa Electric reserves the right to improve, enhance and modify the features and specifications of FITEL products without prior notifications.

## **FURUKAWA ELECTRIC CO., LTD.**

**Japan**  
**Head Office**  
 2-2-3, Marunouchi  
 Chiyoda-ku  
 Tokyo 100-8322, JAPAN  
 Tel: +81-3-3286-3253  
 Fax: +81-3-3286-3978  
<http://www.furukawa.co.jp>  
 Email: [comsales@ho.furukawa.co.jp](mailto:comsales@ho.furukawa.co.jp)

**North America**  
**OFS Fitel, LLC**  
**Specialty Photonics Division**  
 25 Schoolhouse Road  
 Somerset, NJ 08873 USA  
 Tel: +1-732-748-7402  
 Fax: +1-732-748-7436  
<http://www.SpecialtyPhotonics.com>  
 E-mail: [info@SpecialtyPhotonics.com](mailto:info@SpecialtyPhotonics.com)

**Europe**  
**Furukawa Electric Europe Ltd.**  
 3rd Floor, Newcombe House  
 43-45 Notting Hill Gate  
 London W11 3FE, UK  
 Tel: +44-20-7221-6000  
 Fax: +44-20-7313-5310  
<http://www.furukawa-fitel.co.uk>  
 E-mail: [sales@furukawa-fitel.co.uk](mailto:sales@furukawa-fitel.co.uk)

**ASIA**  
**Furukawa Electric Hong Kong Ltd.**  
 Suite 2606, Shell Tower,  
 Times Square, 1 Matheson Street,  
 Causeway Bay, Hong Kong  
 Tel: 852-2512-8938  
 Fax: 852-2512-9717  
<http://www.fehk.com.hk/>  
 E-mail: [guest@fehk.cn](mailto:guest@fehk.cn)