

FOL1xxxMWIx-R4 series

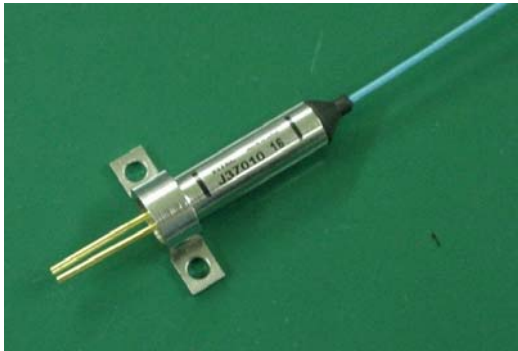

Mar. 2010

Coaxial DFB Laser Module



Applications

- Analog repeater for wireless communication
- CWDM transmission

Descriptions

- FOL1xxxMWIx-R4 series is a coaxial DFB laser module designed for analog repeater for wireless communication.
- The module is a coaxial package with a single mode fiber pigtail, which contains a DFB laser diode, a power monitor photodiode, and an optical isolator.
- This laser module complies with telecom requirements described in Telcordia™ GR-468 and is manufactured in an ISO™9001 certified production line.

Features

- 1310nm, 1550nm and C-WDM (1470~1610nm) wavelength are available
- Wide temperature operation
- Low threshold current
- High side mode suppression ratio
- High output power and low distortion for wireless applications
- Single stage isolator integrated
- RoHS compliant

Absolute Maximum Ratings

Parameter	Symbol	Min.	Max.	Unit	Note
Storage Temperature	Tstg	-40	85	°C	
Operating Case Temperature	Tc	-20	85	°C	S version
		-20	75	°C	
LD Forward Current	IfLD	-	150	mA	
LD Reverse Voltage	VrLD	-	2	V	
PD Forward Current	IfPD	-	5	mA	
PD Reverse Voltage	VrPD	-	20	V	
Soldering Temperature (<10s)	Stemp	-	260	°C	
Relative Humidity	RH	0	85	%	

Specifications (T_c=25°C, unless otherwise specified)

Parameter	Symbol	Min.	Typ.	Max.	Unit	Condition
Threshold Current	I _{th}	-	8	15	mA	CW
		-	-	50	mA	CW, T _c =over temperature
Optical Output Power	Pop ^{*1}	-	4.0	-	mW	CW
Slope Efficiency	η	0.12	0.14	-	W/A	Pop, CW
LD Operating Current	I _{op}	-	-	50	mA	Pop, CW
LD Forward Voltage	V _f	-	1.1	1.5	V	Pop, CW
Peak Wavelength	λ _p	1300	1310	1320	nm	13F1 ; Pop, CW, T _c =25°C
		1540	1550	1560	nm	15F5 ; Pop, CW, T _c =25°C
		λ _p -3	λ _p ^{*2}	λ _p +3	nm	1xQx ; Pop, CW, T _c =25°C
Side Mode Suppression Ratio	SMSR	30	-	-	dB	Pop, CW, T _c =over temperature
Cut-off Frequency	f _r	-	3	-	GHz	Pop
Third Order Distortion	IMD3	-	-	-56	dBc	2 tone test, f ₁ =2200MHz, f ₂ =2202.5MHz, OMI=20%/tone, Pop
Relative Intensity Noise	RIN	-	-154	-145	dB/Hz	Pop, CW, OpRL<-40dB ^{*3} , f=2200MHz
Monitor PD Current	I _m	100	-	2000	μA	V _r PD=5V, Pop, CW
Monitor PD Dark Current	I _d	-	-	100	nA	V _r PD=5V
Monitor PD Capacitance	C	-	-	10	pF	V _r PD=5V, f=1MHz
Isolation	I _{so}	30	-	-	dB	
Tracking Error	TE	-1	-	1	dB	I _m =constant, T _c =over temperature

Note: *1 The symbol 'Pop' denotes the typical value.

*2 λ_p: **13Q1**:1310nm, **14Q7**:1470nm, **14Q9**:1490nm, **15Q1**:1510nm, **15Q3**:1530nm,
15Q5:1550nm, **15Q7**:1570nm, **15Q9**:1590nm, **16Q1**:1610nm
Wavelength tolerance can be customized.

*3 OpRL: Optical Return Loss

FOL1xxxMWIx-R4 series



Mar. 2010

Dimensions and pin assignments

Unit: mm

Tolerance: +/-0.1mm, unless otherwise specified.

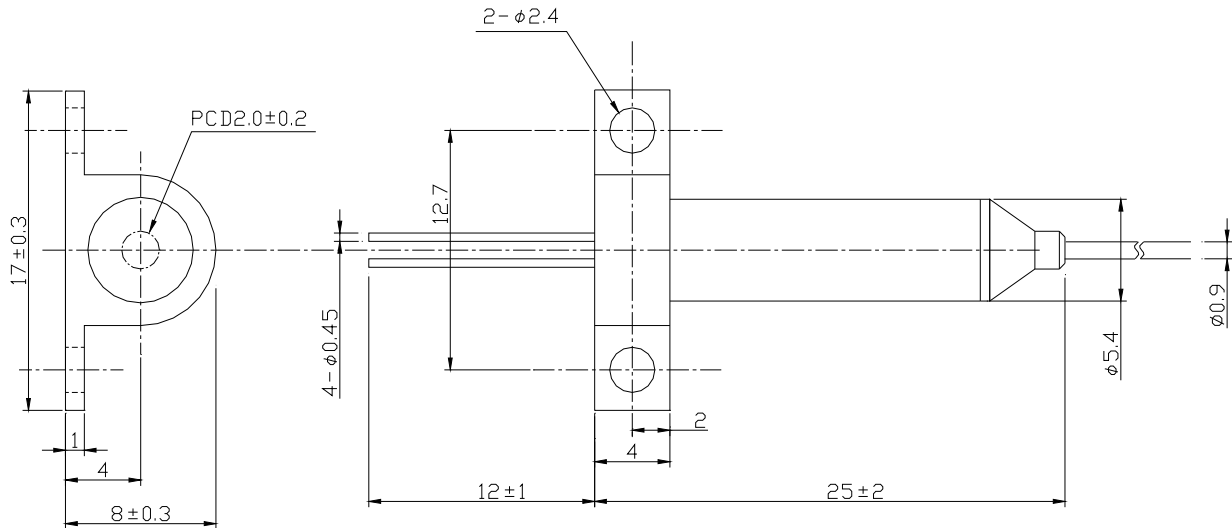

Y7

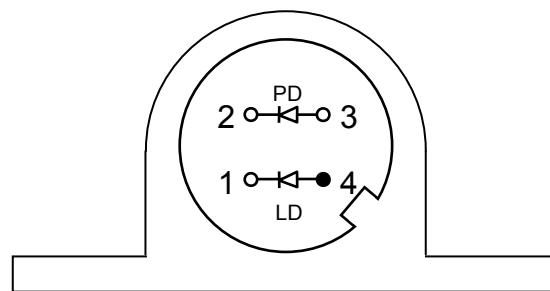

Bottom view, No.4 Pin is Case GND

Fiber pigtail specifications

Parameter	Symbol	Min.	Typ.	Max.	Unit
Fiber Type		Single Mode Fiber, Flame Retardant Hytel Coating			
Cladding Diameter	Dcl	122	125	128	μm
Mode Field Diameter	Dmf	-	10	-	μm
Coating Diameter	Dbc	-	0.9	-	mm
Pigtail Length *4	Lf	1.0	1.1	1.2	m
Bending Radius	Rb	30	-	-	mm
Connector Type		FC/SPC			
		SC/SPC			
		No connector			

Note: *4 From the ferrule-end to the bottom of the TO-Header

Ordering information

FOL□□□□MWI□-R4-□7

Wavelength	
13F1	1310nm
15F5	1550nm
13Q1	1310nm
14Q7	1470nm
14Q9	1490nm
15Q1	1510nm
15Q3	1530nm
15Q5	1550nm
15Q7	1570nm
15Q9	1590nm
16Q1	1610nm

Operating case temperature	
S	-20~+85°C
(blank)	-20~+75°C

Connector	
F	FC/SPC
S	SC/SPC
N	No connector

Safety information

This product complies with 21 CFR 1040.10 and 1040.11, Class 3b laser product. Invisible laser radiation is emitted from the end of the fiber or connector. Avoid direct exposure to the beam.



Telcordia is a trademark of Telcordia Technologies, Inc.
 ISO is a trademark of The International Organization for Standardization.
 Hytel is a trademark of DuPont.

Furukawa Electric reserves the right to improve, enhance and modify the features and specifications of FITEL products without prior notifications.

FURUKAWA ELECTRIC CO., LTD.

Japan
Head Office
 2-2-3, Marunouchi
 Chiyoda-ku
 Tokyo 100-8322, JAPAN
 Tel: +81-3-3286-3253
 Fax: +81-3-3286-3978
<http://www.furukawa.co.jp>
 Email:comsales@ho.furukawa.co.jp

North America
OFS Fitel, LLC
Specialty Photonics Division
 25 Schoolhouse Road
 Somerset, NJ 08873 USA
 Tel: +1-732-748-7402
 Fax: +1-732-748-7436
<http://www.SpecialtyPhotonics.com>
 E-mail:info@SpecialtyPhotonics.com

Europe
Furukawa Electric Europe Ltd.
 3rd Floor, Newcombe House
 43-45 Notting Hill Gate
 London W11 3FE, UK
 Tel: +44-20-7221-6000
 Fax: +44-20-7313-5310
<http://www.furukawa-fitel.co.uk>
 E-mail:sales@furukawa-fitel.co.uk

ASIA
Furukawa Electric Hong Kong Ltd.
 Suite 2606, Shell Tower,
 Times Square,1 Matheson Street,
 Causeway Bay, Hong Kong
 Tel: 852-2512-8938
 Fax: 852-2512-9717
<http://www.fehk.com.hk/>
 E-mail: guest@fehkn