

INPHENIX

16XXnm Distributed Feedback Laser diode Device

IPDFD16XX (1665/1653nm)

Features

- High output power
- Narrow Linewidth
- High side mode suppression

Applications

- Fiber Optic Sensor
- Methane Sensor

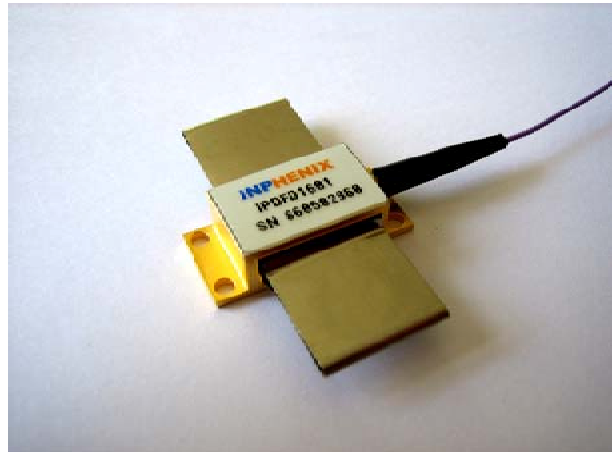

IPDFD16XX Distributed Feedback Laser Device Specifications

Parameter	Symbol	Min.	Typ.	Max.	Unit	Test Condition
Threshold current	I_{th}	–	10	25	mA	CW
Operating current	I_{op}	–	–	80	mA	CW, $P_f = P_{op}$
Output power	P_{op}	3	5	–	mW	CW, $I = I_{op}$
Slope efficiency	S_e	0.15	0.23	–	W/A	CW, $P_f = P_{op}$
Forward voltage	V_f	–	–	2	V	CW, $P_f = P_{op}$
Peak Wavelength(IPDFD1601)	λ_p	1660	1665	1670	nm	CW, $P_f = P_{op}$
Peak Wavelength(IPDFD1602)		1650	1653	1660		
Spectral Width	$\Delta\lambda$	–	–	0.2	nm	CW, $P_f = P_{op}$, 20 dB down
Peak Wavelength Drift	$D\lambda$	–	–	0.14	nm/°C	CW, $P_f = P_{op}$
Side mode suppression ratio	SMSR	35	–	–	dB	CW, $P_f = P_{op}$

INPHENIX

Package Dimensions

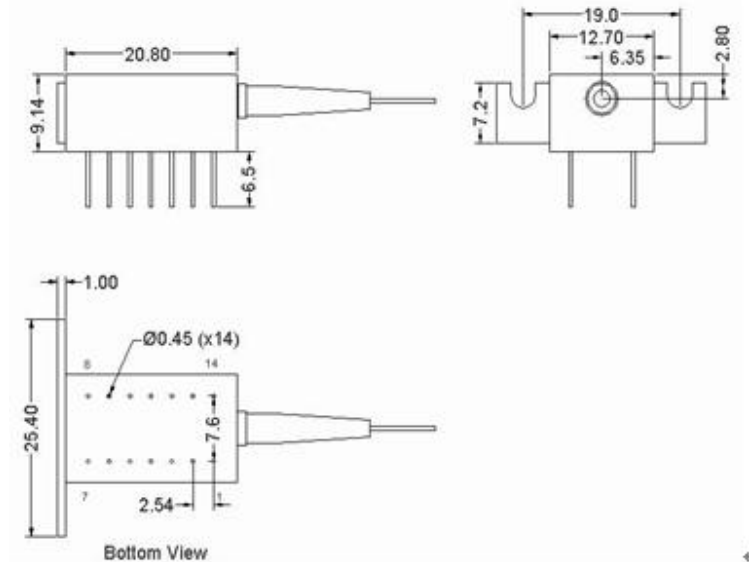

14-Pin DIL Package

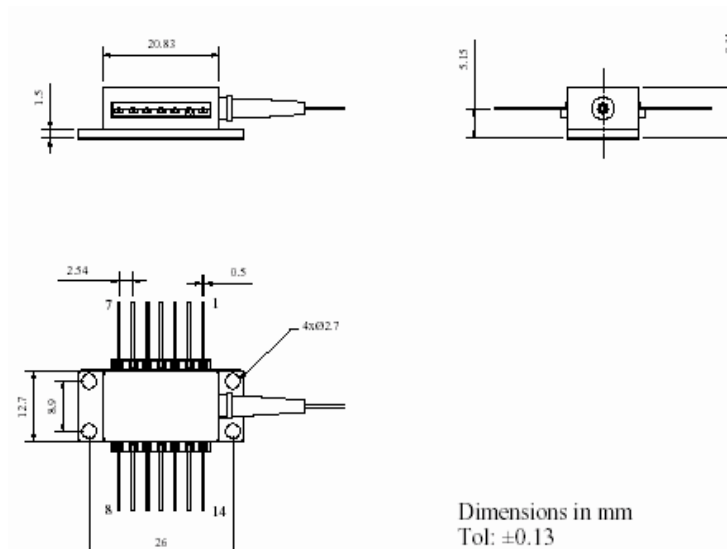

14-Pin BUT Package

All information contained herein is believed to be accurate and is subject to change without notification. No responsibility is assumed. Please contact InPhenix for more information. InPhenix and the InPhenix logo are trademarks of InPhenix Inc.. All rights are reserved.

INPHENIX

Pin Definition

14-pin DIL package				14-pin BUT package			
Pin	Function	Pin	Function	Pin	Function	Pin	Function
1	TEC(+)	8	PD(+)	1	Thermistor	8	NC
2	NC	9	LD(-)	2	Thermistor	9	NC
3	NC	10	Case	3	LD(-)	10	NC
4	NC	11	Thermistor	4	PD(+)	11	case
5	LD(+)	12	Thermistor	5	PD(-)	12	LD(-)
6	NC	13	NC	6	TEC(+)	13	LD(+)
7	PD(-)	14	TEC(-)	7	TEC(-)	14	NC

Absolute Maximum Ratings

Parameter	Min.	Max.	Unit
Operating Temperature	-20	70	°C
Storage Temperature	-40	85	°C
TEC Drive Current		1.5	A
TEC Drive Voltage		3.6	V
Thermistor Resistance	10 k Ω @ 25 °C		
Laser Chip Temperature Setting	25 °C		
Fiber Type	SMF		
Fiber Jacket	900 μ m or 250 μ m tight buffer		
Package	14-pin DIL/14-pin BUT, Others available		

Corporate Office

250 North Mines Rd
 Livermore, CA 94551
 Tel: 925.606.8809
 Fax: 925.606.8810
www.inphenix.com

INPHENIX

Part Numbering Structure

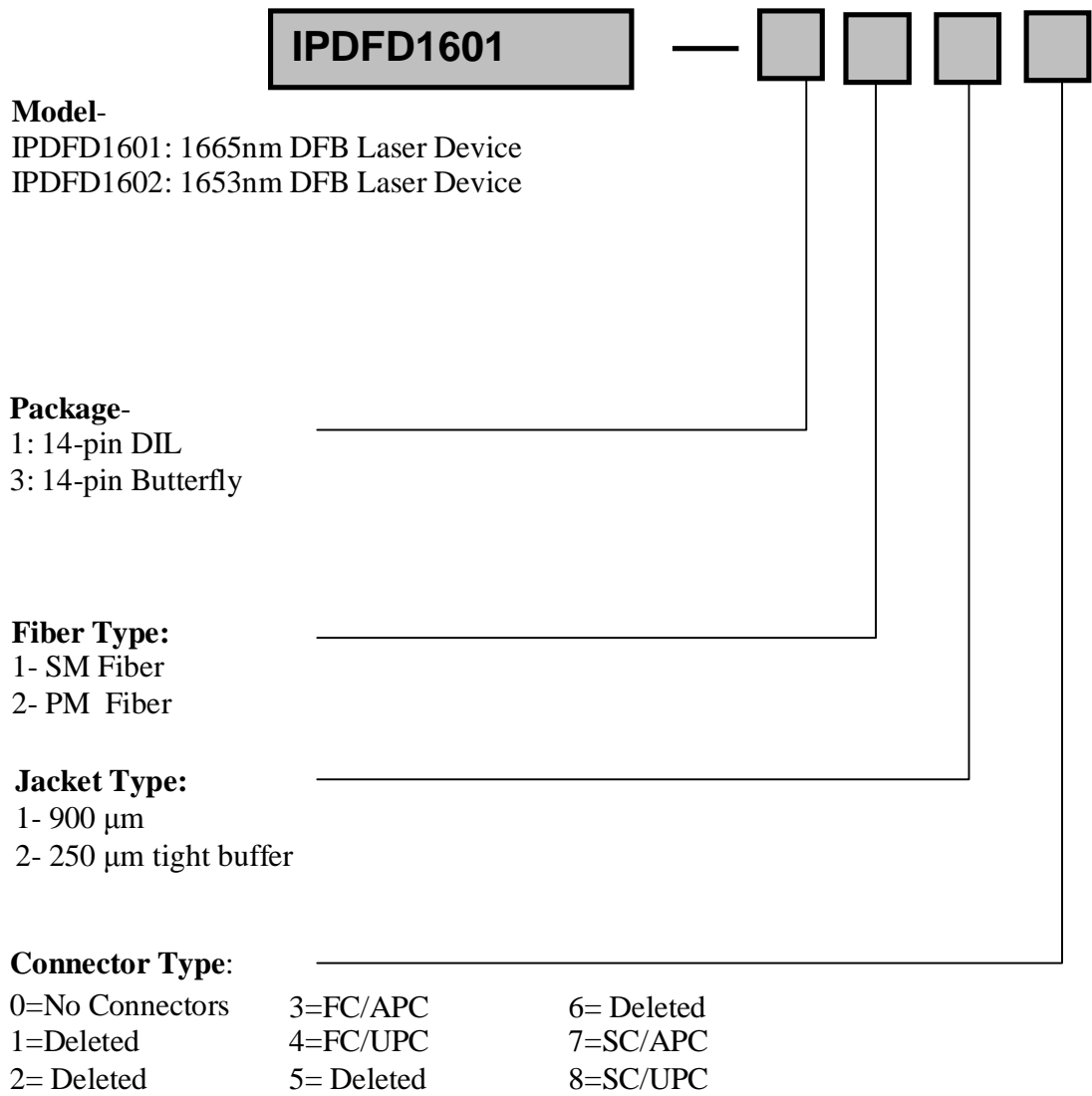

Example: IPDFD1602-1110: 1653nm DFB LD in 14-pin DIL with 900 μ m SM fiber, without connector.