

## RIO ORION™ Laser Source

### A compact and turn-key benchtop laser source based on the industry-proven ORION™ laser module

RIO's ORION™ Laser Source is based on the proven performance of RIO's ORION™ product series. The ORION laser source is designed with the customer's need in mind: user-friendly, highly integrated and turn-key operation.

In addition to unrivaled reliability and performance, the ORION laser-based system provides exceptional value and ease-of-use with up to 20mW output power, very low RIN, ultra low phase noise and narrow linewidth, excellent wavelength stability and fast frequency tuning.

This solution is positioned for reducing the development cycle time and allow for simple integration into R&D lab environments and advanced fiber optic sensing systems. External monitoring and control can be achieved via a Graphical User Interface (GUI) and a USB connection.

The ORION laser source is ideally position as the best ease-of-use system for a multiple of lab-orientated applications where absolute accuracy, stability, lifetime reliability and high resolution are vital, such as remote sensing, distributed temperature, strain, or acoustic fiber optic monitoring, LIDAR and other precision metrology applications.

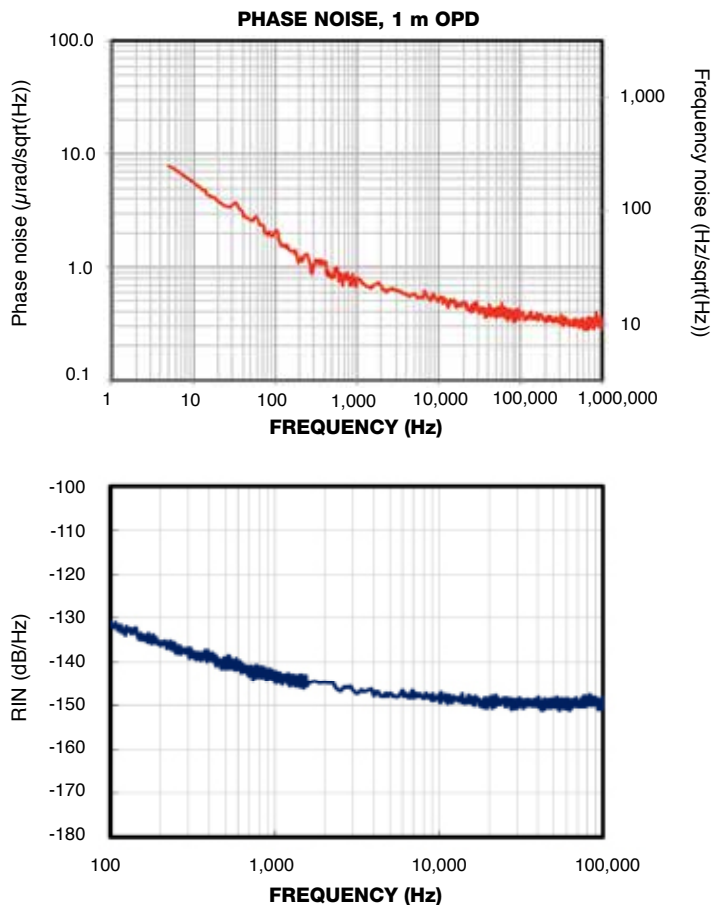

### KEY FEATURES

- Single longitudinal mode
- Ultra low phase noise & RIN
- Low sensitivity to vibration & acoustic noise
- Narrow linewidth (< 1 kHz), long coherence length
- 1530nm-1565nm, ITU-T DWDM wavelength or custom
- Guaranteed mode hop free operation over life & temperature
- Wavelength tunability
- Unrivaled wavelength stability over life & temperature
- Excellent SMSR
- SMF or PMF pigtail options
- CW, modulated and pulsed operations
- 0-70°C operating case temperature
- Telcordia GR-468 Qualified
- RoHS Compliant

## Performance Highlights

PARAMETER	MIN	MAX	UNIT
Output Power	10	20	mW
Center Wavelength (ITU grid)	1530	1565	nm
Thermal wavelength tuning range	30		pm
Relative Intensity Noise		-140	dB/Hz
Polarization Extinction Ratio	20		dB
Modulation bandwidth	DC	100	kHz
Direct frequency modulation range, at 10kHz	200		MHz
Operating temperature range	0	+ 70	°C
Optical Isolation	40		dB

PARAMETER	Grade 1	Grade 3	Grade 4	Grade 5	UNIT
Spectral Linewidth (Lorentzian)	≤15	≤5	≤2	≤1	kHz
Phase Noise Typical @ 200 Hz	22	8	4	2	μrad/rt-Hz 1 m OPD

### Mechanical Diagram

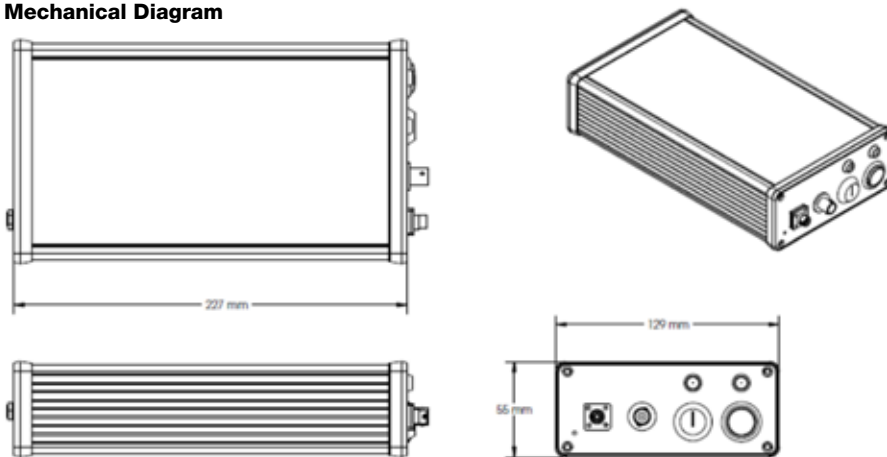

### Ordering Information

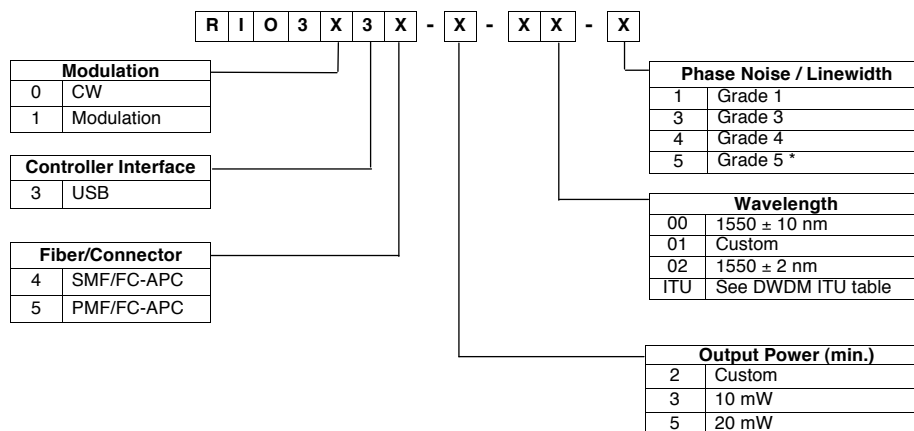

\* Grade 5: 10 mW output power version only

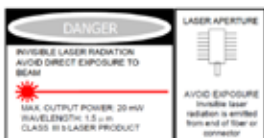

### Laser Safety Information

The ORION Laser Source is classified as FDA/CDRH Class IIIb laser products per CDRH, 21 CFR 1040 laser safety requirements.

## APPLICATIONS

- Acoustic and seismic sensing
  - Defense and security
- Oil & Gas – exploration and production
- LIDAR and remote sensing
- Interferometric fiber optic sensing
  - Metrology
- RF and microwave photonics
  - Coherent communication



### Oil & Gas



### Wind



### Security

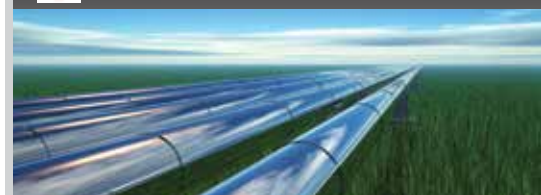

### Infrastructure



### Metrology



For ordering or technical information contact  
**REDFERN INTEGRATED OPTICS INC.**  
 3350 Scott Blvd Bldg 1 | Santa Clara CA 95054 | USA

P 408 970 3500 x 310  
 F 408 970 3200  
 sales@rio-inc.com

