

Micro-Channel Water Cooled Horizontal Array Diode Laser (CW)

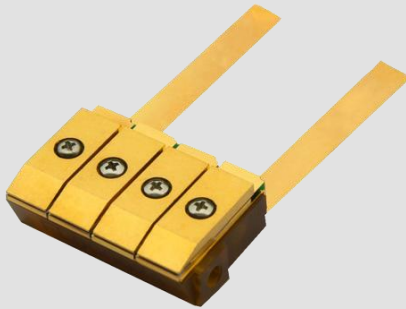

Features

- Long lifetime
- Narrow spectrum
- High power
- Ease of repair

Applications

- Pumping
- Scientific research
- Industry

Device Dimension (mm)

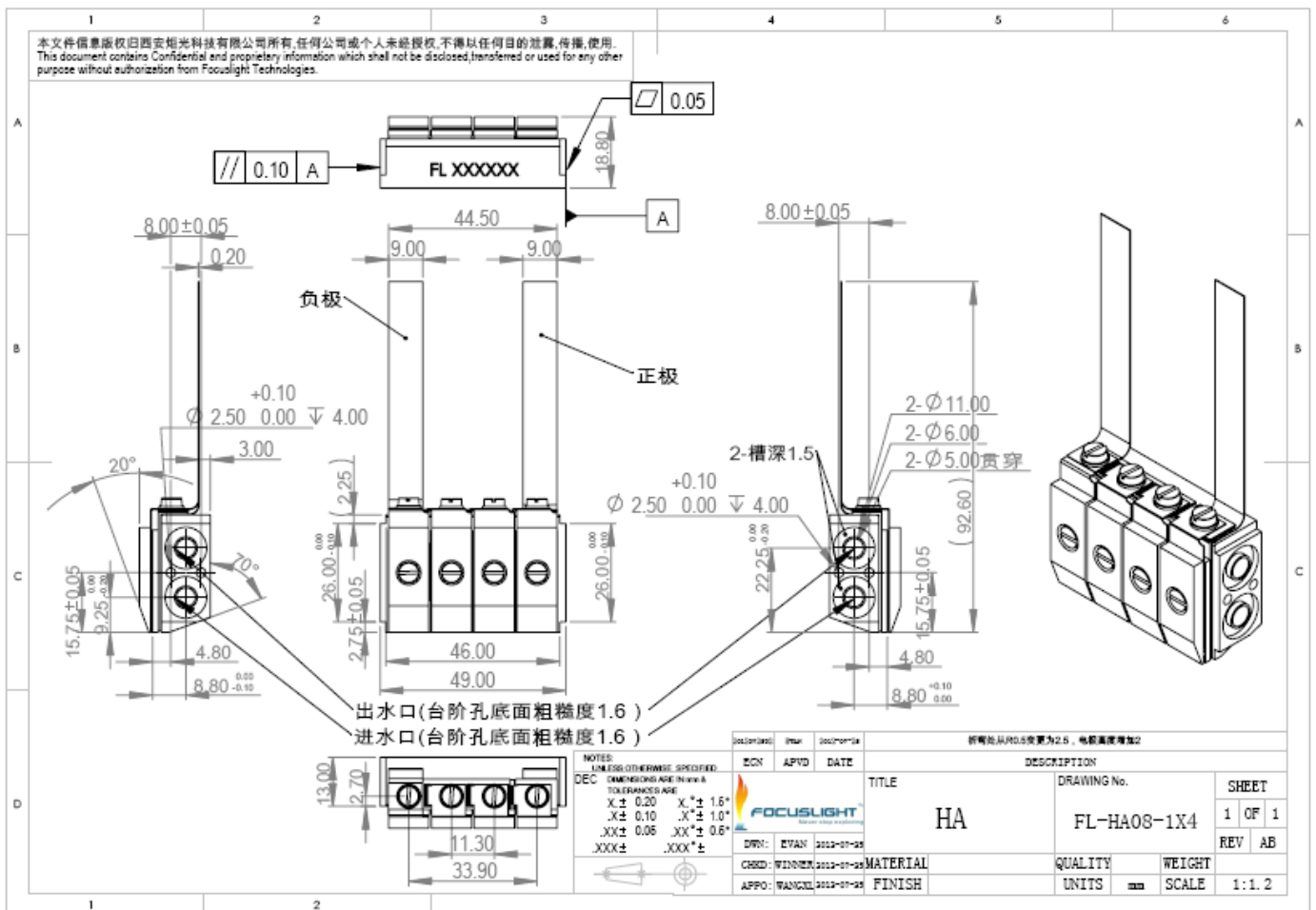

1 This structure drawing is only for reference. For any other special requirement, please feel free to contact us.

2 The above drawings is for 4 bars only. Please contact Focuslight for details.

Micro-Channel Water Cooled Horizontal Array Diode Laser(CW)

Specification

Module Type ¹	Units	FL-HA**-N- ##-792	FL-HA**-N- ##-808	FL-HA**-N- ##-808	FL-HA**-N- ##-808	FL-HA**-N- ##-808
Optical ^{3,5}						
Center Wavelength λ	nm	792	808	808	808	808
Wavelength Tolerance	nm	± 3	± 3	± 3	± 3	± 3
Output Power per Bar ²	W	60	60	80	100	100
Number of bars	#	1~8	1~8	1~8	1~8	1~8
Spectral Width FWHM	nm	≤ 3	≤ 3	≤ 3	≤ 3	≤ 4
Spectral Width FW90%E	nm	≤ 6	≤ 6	≤ 6	≤ 6	≤ 6
Fast Axis Divergence(FWHM)	degree	35	35	35	35	35
Slow Axis Divergence (FWHM)	degree	8	8	8	8	8
Polarization Mode	-	TE	TE/TM	TE	TE	TM
Wavelength Temp. Coefficient	nm/°C	-0.28	-0.28	-0.28	-0.28	-0.28
Electrical Parameters ^{3,5}						
Operating Current I_{op}	A	≤ 70	≤ 72	≤ 90	≤ 123	≤ 123
Threshold Current I_{th}	A	≤ 13	≤ 18	≤ 22	≤ 26	≤ 26
Operating Voltage V_{op}	V	≤ 2	≤ 2	≤ 2	≤ 2	≤ 2
Slope Efficiency	W/A	≥ 1.1	≥ 1.1	≥ 1.05	≥ 1.0	≥ 1.0
Power Conversion Efficiency	%	≥ 48	≥ 46	≥ 48	≥ 42	≥ 42
Thermal Parameters						
Operating Temperature	°C	15~30	15~30	15~30	15~30	15~30
Storage Temperature ⁴	°C	0~55	0~55	0~55	0~55	0~55
Coolant	-	Deionized Water	Deionized Water	Deionized Water	Deionized Water	Deionized Water
Flow Rate/Bar	L/min	0.2~0.5	0.2~0.5	0.2~0.5	0.2~0.5	0.2~0.5
Max Inlet Pressure	kPa	380	380	380	380	380

¹Explanation for the name of Module Type: FL(abbreviation of Focuslight) -HA**(structure code) -N(Number of Bars) -##(Power) -808(center wavelength).

²Reduced lifetime if used above nominal operating conditions.

³Data at 25°C temperature, unless otherwise stated.

⁴A non-condensing environment is required for storage and operation below ambient dew point

⁵If there are any other requirements, please contact us.

Micro-Channel Water Cooled Horizontal Array Diode Laser (CW)

Specification

Module Type ¹	Units	FL-HA**-N- ##-825	FL-HA**-N- ##-880	FL-HA**-N- ##-915	FL-HA**-N- ##-915	FL-HA**-N- ##-940
Optical ^{3,5}						
Center Wavelength λ	nm	825	880	915	915	940
Wavelength Tolerance	nm	± 3	± 3	± 5	± 5	± 5
Output Power per Bar ²	W	60	60	80	120	80
Number of Bars	#	1~8	1~8	1~8	1~8	1~8
Spectral Width FWHM	nm	≤ 3	≤ 3	≤ 4	≤ 5	≤ 4
Spectral Width FW90%E	nm	≤ 6	≤ 6	≤ 7	≤ 8	≤ 7
Fast Axis Divergence(FWHM)	degree	35	35	35	35	35
Slow Axis Divergence (FWHM)	degree	8	8	8	8	8
Polarization Mode	-	TE/TM	TE	TE	TE	TE
Wavelength Temp. Coefficient	nm/°C	~0.28	~0.30	~0.32	~0.32	~0.33
Electrical Parameters ^{3,7}						
Operating Current I_{op}	A	≤ 75	≤ 65	≤ 82	≤ 120	≤ 85
Threshold Current I_{th}	A	≤ 17	≤ 12	≤ 8	≤ 20	≤ 15
Operating Voltage V_{op}	V	≤ 2	≤ 2	≤ 2	≤ 2	≤ 2
Slope Efficiency	W/A	≥ 1	≥ 1.1	≥ 1.05	≥ 1.1	≥ 1.05
Power Conversion Efficiency	%	≥ 48	≥ 55	≥ 52	≥ 50	≥ 52
Thermal Parameters						
Operating Temperature	°C	15~30	15~30	15~30	15~30	15~30
Storage Temperature ⁴	°C	0~55	0~55	0~55	0~55	0~55
Coolant	-	Deionized Water	Deionized Water	Deionized Water	Deionized Water	Deionized Water
Flow Rate/Bar	L/min	0.2~0.5	0.2~0.5	0.2~0.5	0.2~0.5	0.2~0.5
Max Inlet Pressure	kPa	380	380	380	380	380

¹Explanation for the name of Module Type: FL(abbreviation of Focuslight) -HA**(structure code) -N(Number of Bars) -##(Power) -808(center wavelength).

²Reduced lifetime if used above nominal operating conditions.

³Data at 25°C temperature, unless otherwise stated.

⁴A non-condensing environment is required for storage and operation below ambient dew point

⁵If there are any other requirements, please contact us.

Micro-Channel Water Cooled Horizontal Array Diode Laser (CW)

Specification

Module Type ¹	Units	FL-HA**-N- ##-940	FL-HA**-N- ##-940	FL-HA**-N- ##-976	FL-HA**-N- ##-976	FL-HA**-N- ##-976	FL-HA**-N- ##-976
Optical ^{3,5}							
Center Wavelength λ	nm	940	940	976	976	976	976
Wavelength Tolerance	nm	± 5	± 5	± 5	± 5	± 5	± 5
Output Power per Bar ²	W	100	120	60	80	100	120
Number of Bars	#	1~8	1~8	1~8	1~8	1~8	1~8
Spectral Width FWHM	nm	≤ 4	≤ 5	≤ 3	≤ 4	≤ 4	≤ 5
Spectral Width FW90%E	nm	≤ 8	≤ 8	≤ 6	≤ 7	≤ 6	≤ 8
Fast Axis Divergence(FWHM)	degree	35	35	35	35	35	35
Slow Axis Divergence (FWHM)	degree	8	8	8	8	8	8
Polarization Mode	-	TE	TE	TE	TE	TE	TE
Wavelength Temp. Coefficient	nm/°C	~ 0.33	~ 0.33	~ 0.34	~ 0.34	~ 0.34	~ 0.34
Electrical Parameters ^{3,5}							
Operating Current I_{op}	A	≤ 105	≤ 120	≤ 65	≤ 88	≤ 105	≤ 120
Threshold Current I_{th}	A	≤ 8	≤ 20	≤ 7	≤ 9	≤ 7	≤ 20
Operating Voltage V_{op}	V	≤ 2	≤ 2	≤ 2	≤ 2	≤ 2	≤ 2
Slope Efficiency	W/A	≥ 1.05	≥ 1.1	≥ 1.05	≥ 0.95	≥ 0.95	≥ 1.1
Power Conversion Efficiency	%	≥ 50	≥ 50	≥ 55	≥ 52	≥ 52	≥ 50
Thermal Parameters							
Operating Temperature	°C	15~30	15~30	15~30	15~30	15~30	15~30
Storage Temperature ⁴	°C	0~55	0~55	0~55	0~55	0~55	0~55
Coolant	-	Deionized Water	Deionized Water	Deionized Water	Deionized Water	Deionized Water	Deionized Water
Flow Rate/Bar	L/min	0.2~0.5	0.2~0.5	0.2~0.5	0.2~0.5	0.2~0.5	0.2~0.5
Max Inlet Pressure	kPa	380	380	380	380	380	380

¹Explanation for the name of Module Type: FL(abbreviation of Focuslight) -HA**(structure code) -N(Number of Bars) -##(Power) -808(center wavelength).

²Reduced lifetime if used above nominal operating conditions.

³Data at 25°C temperature, unless otherwise stated.

⁴A non-condensing environment is required for storage and operation below ambient dew point

⁵If there are any other requirements, please contact us.



Focuslight Technologies Co., Ltd.

Add: No.17 Xinxu Road, New Industrial Park
Xi'an, Shaanxi, P.R.China 710119

Tel: +86-29 8888 0786

Fax: +86-29 8888 7075

Email: sales@focuslight.com.cn

Website: www.focuslight.com.cn

Copyright ©2009 Focuslight. All rights reserved.

