



Description

The DFB-1xxx-C5-2-A-xx-x-x-xx series of Multi-Quantum Well (MQW) Distributed Feedback (DFB) lasers have been designed specifically analog applications, especially CATV return-path.

The devices feature multiple available wavelengths on the ITU CWDM grid, low distortion characteristics, low RIN noise, and high side mode suppression.

Their uncooled, hermetically sealed, coaxial fiber-pigtailed packages are a cost-effective means of providing a highly linear light source for intermediate-reach and long-reach analog transmission applications.

Features

- ❑ Advanced Multiple Quantum Well (MQW) Distributed Feedback (DFB) Laser Design
- ❑ Low Distortion
 - IMD2 -50 dBc
 - IMD3 -55 dBc
- ❑ RIN < -145 dB/Hz
- ❑ Cost-effective Uncooled Laser Technology
- ❑ SMSR typ. 40 dB
- ❑ 5.6-mm TO-style package with SMF pigtail

Applications

- ❑ CATV Return-path
- ❑ Analog transmission





Absolute Maximum Ratings

Parameter	Symbol	Condition	Min	Max	Unit
Operating Case Temperature	T_c	$I=I_{op}$	-20	85	°C
Storage Temperature	T_{stg}	--	-40	100	°C
Laser Forward Current	--	--	--	120	mA
Laser Reverse Bias	V_r	--	--	2	V
Photodiode Reverse Bias	V_{rpd}	--	--	10	V

Electrical and Optical Characteristics

Parameters are over operating temperature range unless otherwise noted.

Parameter	Symbol	Min	Typ	Max	Unit	Test Conditions
Operating Temperature	T	-20	--	85*	°C	*see order option
Optical Output Power	P_o	--	2.0	--	mW	CW, T=25 °C
Threshold Current	I_{th}	--	--	20 50	mA	T=25 °C T=85 °C
Slope Efficiency	SE	0.08	--	--	mA	T=25 °C
Operating Current	I_{op}	--	--	100	mA	T=85 °C
Forward Voltage	V_F	--	1.1	1.6	V	$P_o=2.0$ mW
Center Wavelength	λ_c	See order options			nm	$P_o=2.0$ mW, CW
Center Wavelength Accuracy	$\Delta\lambda_{acc}$	See order options			nm	$P_o=2.0$ mW, CW, T=25 °C
Spectral Width (-20 dB)	$\Delta\lambda$	--	0.1	1.0	nm	$P_o=2.0$ mW
Wavelength temperature coefficient	$\Delta\lambda/\Delta T$	--	--	0.13	nm/°C	
Side-mode Suppression Ratio	SMSR	30	40	--	dB	$P_o=2$ mW, T=25 °C
Monitor Current	I_{mon}	25	--	375	$\mu A/mW$	$V_R=5$ V
Monitor Dark Current	I_D	--	--	200	nA	$V_R=5$ V
Tracking Error	γ	-1	--	1	dB	$I_{mon}=\text{const}$, $\gamma=10 \log (P_o/2.0)$ [dB]
Optical Isolation	ISO	30	35	--	dB	$P_o=2.0$ mW, CW, T=25 °C



RF Characteristics

Parameter	Symbol	Min	Typ	Max	Unit	Test Conditions
Relative Intensity Noise	RIN			-145	dB/Hz	CW, $P_o=2.0$ mW, $f=5$ MHz to 300 MHz
Relaxation Oscillation Frequency	f_R		4.5		GHz	$P_o=2.0$ mW
Modulation Bandwidth	BW	1.0			GHz	-3 dB, $P_o=2.0$ mW
Second-Order Intermodulation	IMD2			-50	dBc	$T=25$ °C, $P_o=2$ mW, OMI=0.1, Two-tone test, 13 MHz and 19 MHz, 7 dB plus connector loss
Third-Order Intermodulation	IMD3			-55	dBc	$T=25$ °C, $P_o=2.0$ mW, OMI=0.1, Two-tone test, 13 MHz and 19 MHz, 7 dB plus connector loss, all peaks from 5 MHz to 50 MHz meet this level
Carrier-to Noise ratio	CNR	51			dB	$T=25$ °C, $P_o=2.0$ mW, OMI=0.1, ref. To one-tone: 5 MHz to 50 MHz, 7 dB plus connector loss
RF Bandpass Flatness	BF			1.0	dB	Peak to valley, 5 MHz to 300 MHz

DFB-1xxx-C5-2-A-xx-x-x-xx

Dimensions (in mm)

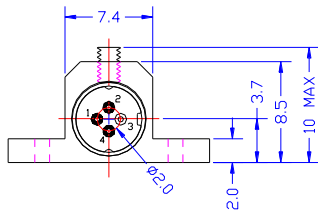
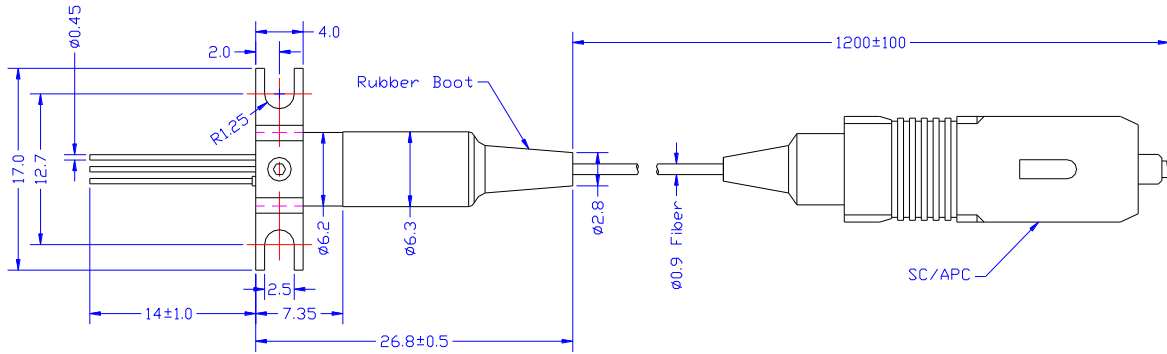

BOTTOM VIEW

TYPE A
PIN ASSIGN:

1	PD Cathode
2	PD Anode
3	LD Anode, GND
4	LD Cathode

TYPE C
PIN ASSIGN:

1	PD Anode
2	LD Anode, PD Cathode
3	GND
4	LD Cathode

Ordering Options:

DFB-1xxx-C5-2-A-xx-x-x-xx

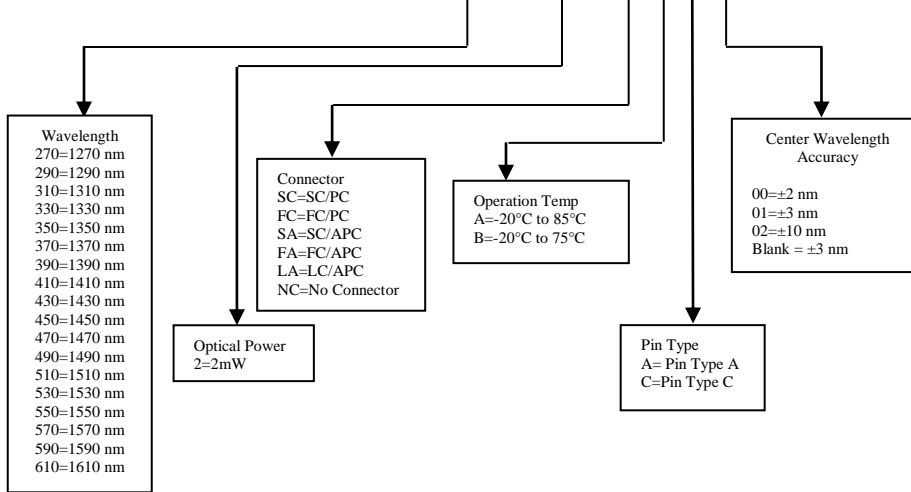

Safety Information

All versions of this laser are Class 1M laser products per IEC¹/EN² 60825-1:2007. Users should observe safety precautions such as those recommended by ANSI³ Z136.1-2000, ANSI Z36.2-1997 and IEC 60825-1:2007.

Notes about Laser Safety Class:

The Food and Drug Administration's Center for Devices and Radiological Health (FDA/CDRH) in the USA has decided to harmonize their requirements with 21 CFR 1040.10 and 1040.11 with the IEC/EN 60825-1 and IEC/EN 60601-2-22 standards. This process has not yet happened and in the interim, the CDRH agency has released '[Laser Notice No.50](#)' to reduce the regulatory burden. This notice allows IEC/EN classification and labeling of lasers within the USA.

IEC¹/EN² 60825-1 Laser Class

Class 1M: laser is safe for all conditions of use except when passed through magnifying optics such as microscopes and telescopes. Class 1M lasers produce large-diameter beams, or beams that are divergent. The MPE for a Class 1M laser cannot normally be exceeded unless focusing or imaging optics are used to narrow the beam. If the beam is refocused, the hazard of Class 1M lasers may be increased and the product class may be changed. A laser can be classified as Class 1M if the total output power is below (IEC/EN) class 3B but the power that can pass through the pupil of the eye is within Class 1.

FDA Laser Class

Class IIIB: moderate power lasers (cw: 5-500 mW, pulsed: 10 J/cm² or the diffuse reflection limit, whichever is lower). In general Class IIIB lasers will not be a fire hazard, nor are they generally capable of producing a hazardous diffuse reflection. Specific controls are recommended.

This product does not conform to 21 CFR 1040.10 and 1040.11. Consequently, this laser module is only intended for use as a component by manufacturers of electronic products and equipment.

Wavelength = 1270 – 1610 nm
 Maximum Power = 75mW
 Single-mode fiber pigtail
 Fiber Numerical Aperture = 0.14

Labeling is not affixed to the laser module due to size constraints; rather, labeling is placed on the outside of the shipping box.

This product is not shipped with a power supply.

Caution: use of controls or adjustments or performance of procedures other than those specified herein may result in hazardous radiation exposure.



classified in accordance with IEC 60825-1:2007

(1) IEC is a registered trademark of the International Electrotechnical Commission

(2) Within Europe the IEC standard has been adopted as a European Normative standard known as EN 60825, and each European country will have its own version of this standard, for example, the British Standards version known as BS EN 60825. There can be small differences between the different countries versions of EN 60825, and these are in part caused by the process of translating the standard into the native language of that country.

(3) ANSI is a registered trademark of the American National Standards Institute