

CW Light Source - Distributed feedback (DFB) lasers -

FEATURES

- \* Semiconductor-based distributed feedback (DFB) lasers for telecom and spectroscopy applications
- \* Available wavelengths range between 1260 nm and 2350nm
- \* High Power or Narrow Linewidth models are available

APPLICATIONS

- \* Telecommunications (DWDM, CWDM)
- \* Test and measurement
- \* Fiber optic sensors
- \* Near - IR gas analysis
- \* Tunable diode laser absorption spectroscopy (TDLAS)

Products Lineup/Model Number

CW-DFB modules

	Wavelength(nm)	Power	
		10mW	20mW
O-band	1260-1360	<a href="#">NLK1B5EAAA</a>	<a href="#">NLK1B5GAAA</a>
E-band	1360-1460	<a href="#">NLK1E5EAAA</a>	<a href="#">NLK1E5GAAA</a>
S-band	1460-1530	<a href="#">NLK1S5EAAA</a>	<a href="#">NLK1S5GAAA</a>
C-band	1530-1565	<a href="#">NLK1C5EAAA</a>	<a href="#">NLK1C5GAAA</a>
L-band	1565-1625	<a href="#">NLK1L5EAAA</a>	<a href="#">NLK1L5GAAA</a>
U-band	1625-1675	<a href="#">NLK1U5EAAA</a>	<a href="#">(NLK1U5FAAA)</a> (15mW)

\* TO-Can PKG are also available

\* Longer wavelength (1675-2350 nm) LDs are also available. Please contact us for details.

## NLK1556STB (S-band)

1460-1530 nm DFB laser diode in a butterfly-type 14 pin package with thermo-electric cooler. Pigtail fiber is connectorized with an FC/PC connector.

### FEATURES

- \* Wavelength Range      1460 - 1530 nm, ITU-T grid wavelength
- \* Fiber Output Power      20mW

### LIMITING VALUES( $T_{sub}=25deg.$ )

Parameter	Symbol	Ratings	Units
Laser diode reverse voltage	$V_R$	2.0	V
Laser diode forward current	$I_F$	225	mA
Operating case temperature	$T_{case}$	-5 to 70	deg.
Storage temperature	$T_{stg}$	-40 to 85	deg.
Photodiode reverse voltage	$V_{DR}$	10	V
Photodiode forward current	$I_{DF}$	10	mA
Peltier current	$I_P$	1.4	A

### ELECTRICAL/OPTICAL CHARACTERISTICS( $T_{sub}=25deg.$ )

Parameter	Symbol	Condition	Min.	Typ.	Max.	Units
Forward voltage	$V_F$	$I_F=30mA$		1.2	1.6	V
Threshold current	$I_{(TH)}$	CW		10	20	mA
Fiber output power	$\phi_e$	CW, $I_F=130mA$	20			mW
Peak wavelength	$\lambda_p$	CW, $\phi_e=20mW$	-1	ITU-T	+1	nm
Spectral linewidth*	$\Delta\nu$	CW, $\phi_e=20mW$		2		MHz
Side mode suppression ratio	SMS	CW, $\phi_e=20mW$	35			dB
Monitoring Current(PD)	$I_{R(E)}$	CW, $\phi_e=20mW$	0.1			mA
Dark current(PD)	$I_{r(0)}$	CW, $V_{DR}=5V$			100	nA
Tracking error	$E_R$	$I_{R(E)}=constant$	-0.5		+0.5	dB
Cooling capacity*	$\Delta T_{PE}$	$\phi_e=20mW, T_{case}=70deg$	45			deg.
Peltier current	$I_{PE}$	$T_{case}=-5$ to 70deg.			1	A
Peltier voltage	$V_{PE}$	$T_{case}=-5$ to 70deg.			2	V
Thermister resistance*	R	$T_{sub}=25deg.$		10		k $\Omega$
Isolation*	$I_s$	$T_{sub}=25deg.$		30		dB

$$\Delta T = |T_{case} - T_{sub}|$$

\* Data is not attached.



### WARNING

If you plan to use these products in equipment which could endanger lives in the event of a product failure, please consult an NEL engineer before usage. Improper application of these products may endanger life. To avoid possible injury, make certain these products are used in a redundant configuration.

- 1 These products are subject to export regulations and restrictions set force by the Japanese Government.
- 2 NTT Electronics Corporation reserves the right to make changes in design, specification or related information at any time without prior notice.

Module Type : STB



Outline Diagram [mm]

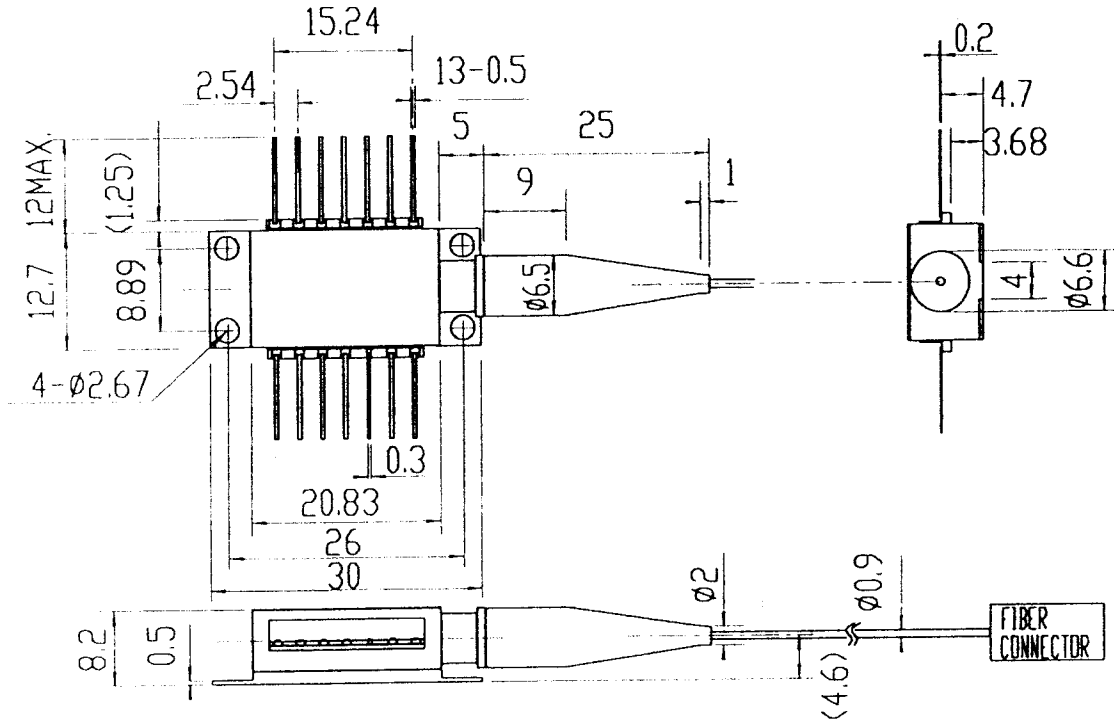

Schematic Diagram (Top View)

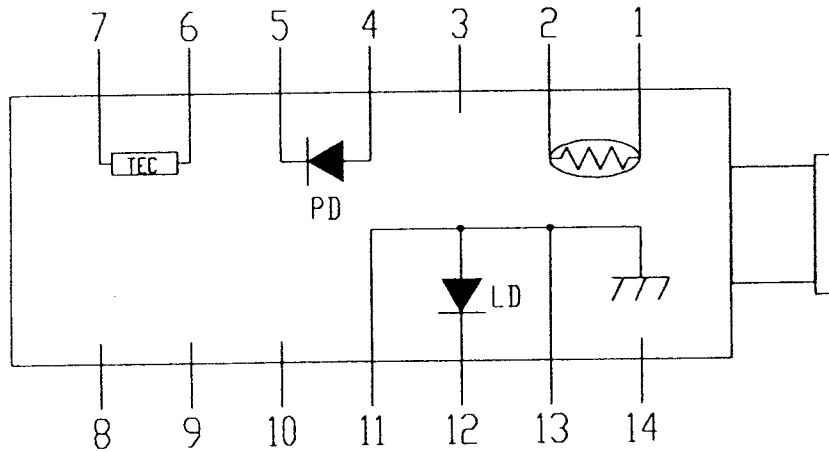

Pin Connection

No.	Description	No.	Description
1	Thermistor	8	NC
2	Thermistor	9	NC
3	NC	10	NC
4	PD Anode (-)	11	Case Ground
5	PD Cathode (+)	12	LD Cathode (-)
6	Cooler (+)	13	Case Ground (LD Anode)
7	Cooler (-)	14	NC