



PART NUMBER 0915L-16A  
 ITEM NAME 915 NM LASER (DIODE; SMA PORT)

## PRODUCT DATASHEET



### DESCRIPTION

915 nm laser with SMA output is a very compact high performance laser source for multimode fiber installations. Fiber could be supplied optionally.

### SPECIFICATIONS

Specifications updated: 8 February 2021

Parameter	Minimum Value	Typical Value	Maximum Value
Central Wavelength, nm	910	915	920
Longitudinal modes	-	Multiple	-
Spectral line width FWHM, nm	0.02	0.5	1.5
Output power, mW	-	140 <sup>1</sup>	170
Fiber coupling efficiency, %	50	70 <sup>2</sup>	80
Fiber core diameter, $\mu\text{m}$	50	105	200
Power stability, % (RMS, 8 hrs)	0.01	0.05 <sup>3</sup>	0.25
Power stability, % (peak-to-peak, 8 hrs)	0.05	0.2 <sup>4</sup>	1
Noise, % (RMS, 20 Hz to 20 MHz)	-	0.25 <sup>5</sup>	0.6
Transversal modes	-	Multiple	-
Control interface type	-	UART <sup>6</sup>	-
Operation mode	-	APC (CW)	-
Modulation bandwidth, MHz	-	10 <sup>7</sup>	-
Input voltage, VDC	4.8	5	5.3
External power supply requirement	-	+5 V DC, 1.5 A	-
Dimensions, mm	-	50 x 30 x 18 <sup>8</sup>	-
Heat-sinking requirement, °C/W	-	1	-
Optimum heatsink temperature, °C	15	20	30
Warm up time, mins (cold start)	0.1	0.5	1
Temperature stabilization	-	Internal TEC	-
Overheat protection	-	Yes	-
Storage temperature, °C (non-condensing)	-10	-	50
Net weight, kg	0.1	0.12	0.14

### TYPICAL SPECTRUM

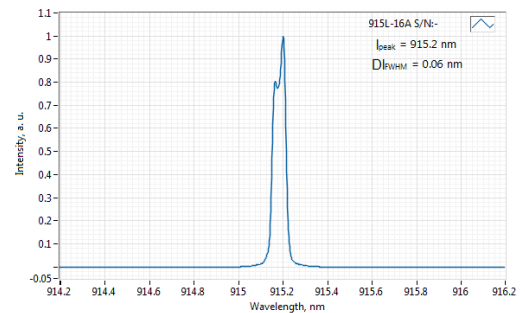

Typical spectrum of 0915 nm diode laser. Measured with 20 pm resolution.

### DRAWING

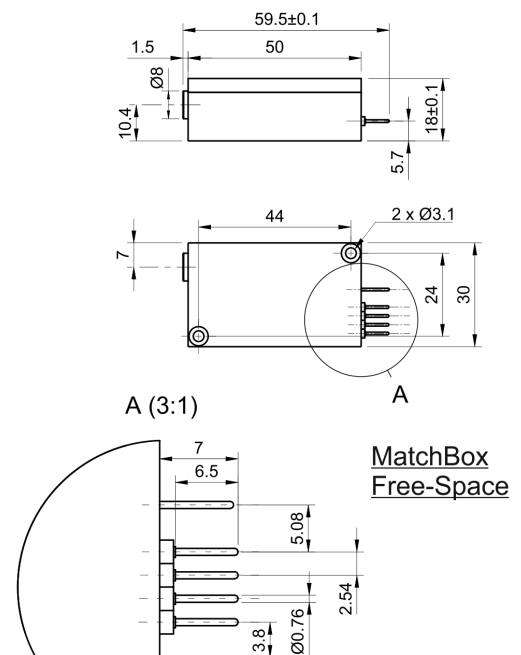

Max. power consumption, W	0.4	2	10
Warranty, months (op. hrs)	-	14 (10000) <sup>9</sup>	-
Laser Safety Class	-	3B	-
RoHS	-	Yes	-
CE compliance	-	- General Product Safety Directive (GPSD) 2001/95/EC - (EMC) Directive 2004/108/EC	-
OEM lasers are not compliant with	-	IEC60825-1:2014 (compliant using additional accessories)	-
Country of origin	-	Lithuania	-

<sup>1</sup> The optical power can be tuned from virtually 0% to 100%. However, other specifications, such as central wavelength, power stability, noise, polarization ratio, beam shape, quality and circularity are not guaranteed at power levels other than factory preset power. Significantly worse power stability is to be expected at very low power levels, e.g. <3% from specified nominal power.

<sup>2</sup> Output power is heavily dependent on fiber insertion repeatability.

<sup>3</sup> The long term power test is carried out at constant laser body temperature (+/-0.1 °C) using an optical power meter with an input bandwidth of 10 Hz. The actual measurement rate has a period of about 20 seconds to 1 minute.

<sup>4</sup> The long term power test is carried out at constant laser body temperature (+/-0.1 °C) using an optical power meter with an input bandwidth of 10 Hz. The actual measurement rate has a period of about 20 seconds to 1 minute.

<sup>5</sup> Noise level is measured with a fast photodiode connected to an oscilloscope. The overall system bandwidth is from 2 kHz to 20 MHz.

<sup>6</sup> Break-out-boxes AM-C8 and AM-C3 can be used for conversion of UART communication to either USB or RS232.

<sup>7</sup> TTL digital modulation up to 10 MHz.

<sup>8</sup> Excluding control interface pins and an output window/fiber assembly.

<sup>9</sup> Whichever occurs first. The laser has an integrated operational hours counter.

Note: Product specifications are subject to change without prior notice to improve reliability, function or design or otherwise.