

Preliminary DATA SHEET

DFB LASER DIODE LC TOSA

DFB-1310-10LR-LC

FEATURES:

- 10Gbps 1310nm DML
- RWG DFB laser
- Very low power dissipation
- 50 Ohm impedance matching inside the laser package
- Differential electrical interface
- Anti-wiggle receptacle

APPLICATION

- Designed for SONET and Gigabit Ethernet
 - ◆ Compatible with all 10Gb MSAs (XFP, X2, XPAK, XENPAK)

The DFB-1310-10LR-LC is specifically designed for applications based on several optical communications standards, including IEEE 10GBASE-LR, STM64, STM64 FEC, 10GFC, 10G GbE, 10G GbE FEC, & 10GFC FEC. Excellent optical performance is achieved by matching the electrical characteristics of the TOSA and laser to the external circuitry. Separate, differential laser bias and modulation pins significantly reduce the amount of electrical power required at the module level, and help to reduce the overall electro-magnetic emissions. The TOSA is designed to be paired with the 10G LR ROSA PIN-1310-10LR-x available at <http://www.finisar.com/aoc.php>.



Part Number	Description
DFB-1310-10LR-LCA	10Gb DFB laser in LC TOSA

ABSOLUTE MAXIMUM RATINGS

Parameter	Rating
Storage Temperature	-40°C to +85°C
Case Operating Temperature	-5°C to +85°C
Lead Solder Temperature	260°C, 10 seconds
Continuous Optical Power	20mW
Diode Reverse Voltage	2V
Laser Diode Continuous Forward Current	130mA
Monitor Photodiode Reverse Current	2mA
Monitor Photodiode Reverse Voltage	10V

NOTICE: Stresses greater than those listed under "Absolute Maximum Ratings" may cause permanent damage to the device. This is a stress rating only and functional operation of the device at these or any other conditions above those indicated in the operations section for extended periods of time may affect reliability.

NOTICE: The inherent design of this component causes it to be sensitive to electrostatic discharge (ESD). To prevent ESD-induced damage and/or degradation to equipment, take normal ESD precautions when handling this product



ELECTRICAL-OPTICAL CHARACTERISTICS

Unless otherwise stated, all parameters are at $T_{CASE} = 25^{\circ}C$, $T_{RANGE, CASE} = -5$ to $85^{\circ}C$, 10.3125 Gbps, PRBS 2³¹-1

Parameter	Test Conditions	Symbol	Min.	Typ.	Max.	Units	Notes
Threshold Current	$T = 25^{\circ}C$ $T = T_{RANGE}$	I_{TH}		8	35	mA	
Operating Current	$T = 25^{\circ}C$ $T = T_{RANGE}$	I_{OP}		35	70	mA	1
Modulation Current	$T = 25^{\circ}C$ $T = T_{RANGE}$	I_{MOD}		25	60	mA	ER~4.5dB ER~6.5dB
Output Power	$I_F = I_{OP}$	L_{OP}	-3.5		-1.0	dBm	2
Slope Efficiency	$T = 25^{\circ}C$, SMF	η		0.023		mW/mA	
Extinction Ratio	$T = T_{RANGE}$		3.5		6.5	dB	3
LA (wiggle)		LA			1.5	dB	4
Wavelength	$T = 25^{\circ}C$	λ	1291		1329	nm	
Spectral Width (-20dB)	$T = T_{RANGE}$	$\Delta\lambda$			1.0	nm	
Wavelength temperature coefficient		$\Delta\lambda/\Delta T$		0.09		nm/ $^{\circ}C$	
Side Mode Suppression	$T = T_{RANGE}$	SMSR	35			dB	5
Transmitter Reflectance		RL			-25	dB	
Mask Margin	$T = 25^{\circ}C$ $T = T_{RANGE}$	MM			12 10	%	6
Rise / Fall Time		T_r T_f		35 45		ps	6
Forward Voltage	$I = I_{OP}$, $T = T_{RANGE}$	V_f	1		1.6	V	
TOSA Input Resistance	$I = I_{OP}$, $T = T_{RANGE}$	R_{DIFF}	30	34	40	Ohms	7
Monitor Current	$T = 25^{\circ}C$, $I = I_{OP}$, $V_B = -2.5V$	I_{MON}	25		1000	μA	
Power Tracking Error	$I_{MON} = \text{Constant}$	TE	-1.5		1.5	dB	8
Monitor Dark Current	$T = 25^{\circ}C$, $V_B = -2.5V$ $T = T_{RANGE}$, $V_B = -2.5V$	I_D			10 100	nA	
Monitor Diode Capacitance	$V_B = -2.5V$	C_{MON}			10	pF	
Optical Return Loss Tolerance		ORL	12			dB	
Differential Return Loss	0.1 < f < 7.5 GHz 7.5 < f < 12.5 GHz	S_{DD11}			-10 -6	dB	
Case to Signal Isolation		R_{ISO}	10			K ohms	

Notes:

1. Operating current is the average bias current required to meet the ER, rise/fall, and bandwidth specifications. The target operating condition is 35 mA over threshold at high temperature, 30mA over threshold at RT.
2. Output power specification is defined into single-mode fiber(SMF 28).
3. TOSA would be capable of meeting other specifications when modulated over this ER range.
4. Maximum change in power as fiber is rotated by 360°.

Continued...

Notes continued...

5. SMSR is measured at Current => $I_{th} + 8mA$ at $-5C$, $25C$ is $I_{th} + 10mA$ and $85C$ $I_{th} + 13mA$

6. Measured with an optical receiver with a 10.7 Gb/s filter (4th order Bessel-Thomson filter with 3 dB bandwidth = $0.75 \times \text{bitrate}$).

7. Includes the impedance matching network and the DFB intrinsic impedance

8. Tracking error is defined as the coupled power difference at T_{max} or T_{min} (relative to $25^{\circ}C$) where the back monitor current, I_{mon} , is held constant at the value found at $25^{\circ}C$ at $I=I_{op}$.

PIN OUT

Number	Function
1	Laser BIAS+
2	MPD Cathode
3	Ground
4	Laser MOD+
4	Laser MOD-
4	Ground
4	MPD Anode
4	Laser BIAS-

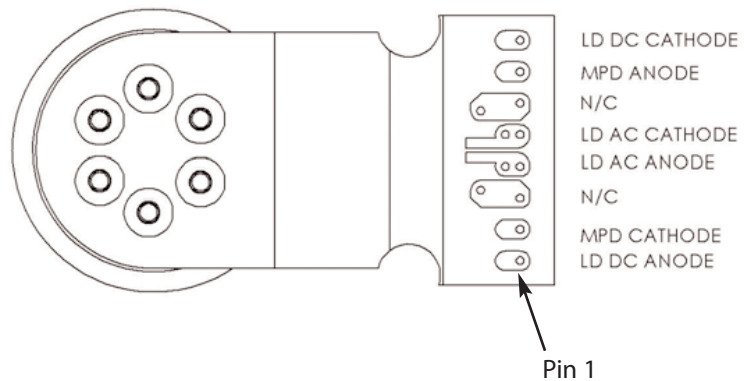

INTERNAL SCHEMATIC

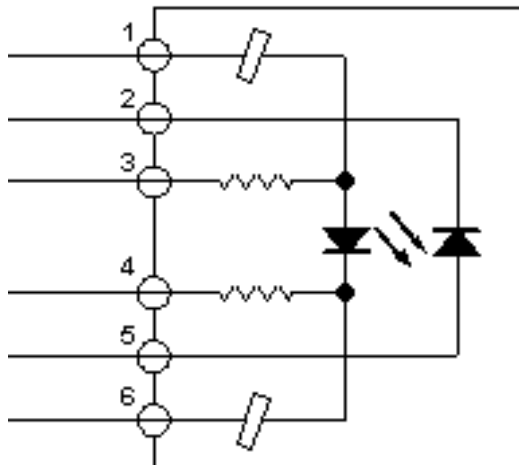

TYPICAL PERFORMANCE CHARACTERISTICS

10.7Gbps, SONET Mask

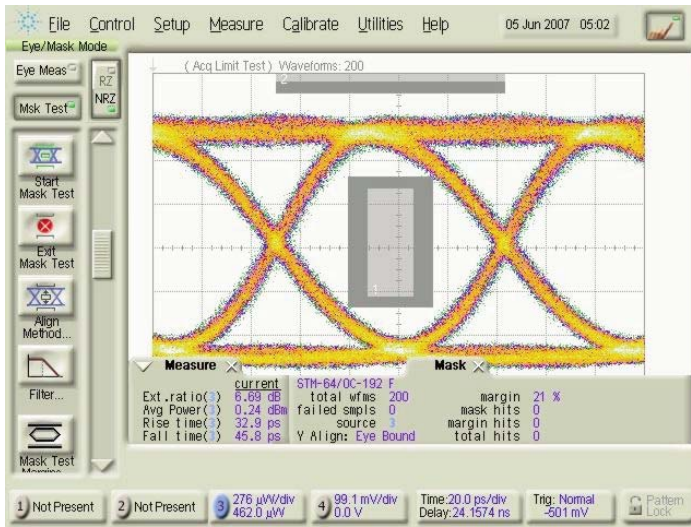

-5C

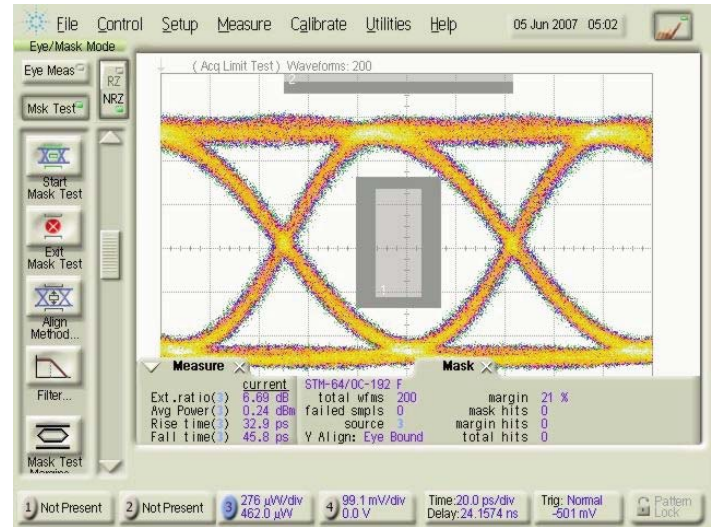

-85C

FLEX MOUNTING DIMENSIONS

Dimensions in Inches

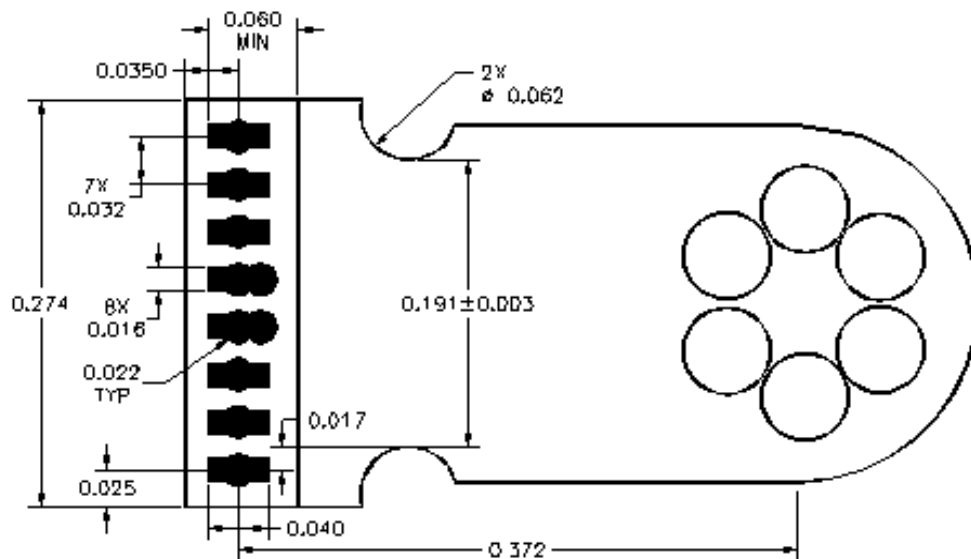

DFB-1310-10LR-SCA LC MOUNTING DIMENSIONS

Dimensions in mm [inches]

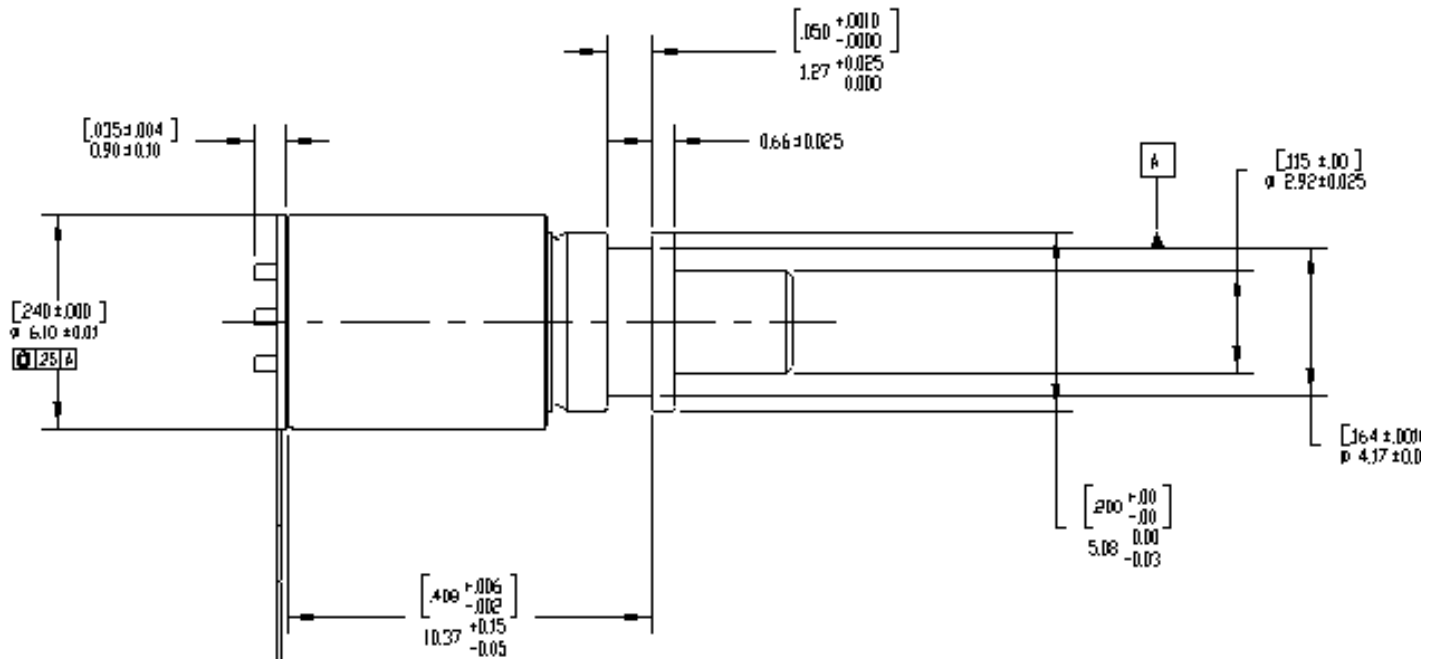

ADVANCED OPTICAL COMPONENTS

Finisar's ADVANCED OPTICAL COMPONENTS division was formed through strategic acquisition of key optical component suppliers. The company has led the industry in high volume Vertical Cavity Surface Emitting Laser (VCSEL) and associated detector technology since 1996. VCSELs have become the primary laser source for optical data communication, and are rapidly expanding into a wide variety of sensor applications. VCSELs' superior reliability, low drive current, high coupled power, narrow and circularly symmetric beam and versatile packaging options (including arrays) are enabling solutions not possible with other optical technologies. ADVANCED OPTICAL COMPONENTS is also a key supplier of Fabry-Perot (FP) and Distributed Feedback (DFB) Lasers, and Optical Isolators (OI) for use in single mode fiber data and telecommunications networks

LOCATION

- Allen, TX - Business unit headquarters, VCSEL wafer growth, wafer fabrication and TO package assembly.
- Fremont, CA – Wafer growth and fabrication of 1310 to 1550nm FP and DFB lasers.
- Shanghai, PRC – Optical passives assembly, including optical isolators and splitters.

SALES AND SERVICE

Finisar's ADVANCED OPTICAL COMPONENTS division serves its customers through a worldwide network of sales offices and distributors. For application assistance, current specifications, pricing or name of the nearest Authorized Distributor, contact a nearby sales office or call the number listed below.

Finisar
Advanced Optical Components Division

Phone: 1-866-MY-VCSEL USA (toll free)
1-214-509-2700 USA (Direct dial)
44 (0) 174 336 5533 Europe
886-935-409898 China & Taiwan
81-90-4437-1130 Japan
82-11-220-6153 Asia Pacific & Korea

Fax: 1-214-509-3709 USA

Email: salesAOCD@finisar.com
WEB: www.finisar.com/aoc.php

AOC CAPABILITIES

ADVANCED OPTICAL COMPONENTS' advanced capabilities include:

- 1, 2, 4, 8, and 10Gbps serial VCSEL solutions
- 1, 2, 4, 8, and 10Gbps serial SW DETECTOR solutions
- VCSEL and detector arrays
- 1, 2, 4, 8, and 10Gbps FP and DFB solutions at 1310 and 1550nm
- 1, 2, 4, 8, and 10Gbps serial LW DETECTOR solutions
- Optical Isolators from 1260 to 1600nm range
- Laser packaging in TO46, TO56, and Optical subassemblies with SC, LC, and MU interfaces for communication networks
- VCSELs operating at 670nm, 780nm, 980nm, and 1310nm in development
- Sensor packages include surface mount, various plastics, chip on board, chip scale packages, etc.
- Custom packaging options