

FiberMax™ Module

FMXL785-040-XXXA/B 785nm, 40mW



Description

FiberMax single-mode fiber-pigtailed laser modules deliver superior performance for today's demanding electro-optic applications. Based on Blue Sky Research CircuLaser™ technology, the FiberMax package provides the highest fiber output power level achieved from its laser diode source by any commercially available single-mode fiber-pigtailed package. Using a unique Blue Sky Research package design, FiberMax outputs are amongst the most thermally stable available. The FiberMax line offers a wide range of wavelengths and power levels to fit customer requirements. In addition the units are offered with PM fiber, 3mm jacketing, a range of collimator options, and two pin-outs. FiberMax fiber-coupled modules are competitively priced and backed by Blue Sky Research customer support.



Optical and Electrical Characteristics*

Item	Symbol	Unit	Min	Typ	Max	Test Condition
Optical output power	P _O	mW	40	50		T _c =25°C
Threshold current	I _{TH}	mA		30	50	T _c =25°C
Operating current	I _{OP}	mA		100	140	T _c =25°C
Operating voltage	V _{OP}	V		2.2	2.8	T _c =25°C
Lasing wavelength	λ	nm	775	785	800	T _c =25°C
Monitor current	I _{MON}	mA	0.1	0.25	0.6	P _o , T _c =25°C

Absolute Maximum Rating

Item	Symbol	Unit	Min	Max	Test Condition
Operating temperature	T _{OPR}	°C	-10	+60	
Storage temperature	T _{STG}	°C	-40	+85	
LD reverse voltage	V _R (LD)	V		2	T _c =25°C
PD reverse voltage	V _R (PD)	V		30	T _c =25°C

Fiber Specs

Single mode fiber w/ 3mm or 900um protective jacket

Item	Symbol	Unit	Min	Typ	Max
Fiber numerical aperture	NA			0.13	
Mode Field Diameter @ 850nm	MFD	um	4.5	5.0	5.5
Length	L	meter	-	1	-

Polarization maintaining fiber w/ 3mm or 900um protective jacket

Item	Symbol	Unit	Min	Typ	Max
Fiber numerical aperture	NA			0.11	
Length	L	meter	-	1	-
Polarization Extinction Ratio	PER	dB	17	20	

Collimator Options

Type	M	N	P	Q
Beam Diameter (1/e ² , mm, ±25%)	0.8	1.3	1.9	3.2
Divergence (mrad)	<1.2	<0.8	<0.5	<0.4

**Specifications are subject to change without notice*

. Ordering Information

FMXL -785-040- A/B

Product Family _____

Fiber/Cable Type _____

S = single mode / 3mm jacket
P = polarization maintaining / 3mm jacket
T = single mode / 900 um jacket
M = polarization maintaining / 900 um jacket

Fiber Connector _____

0 = No connector
F = FC/PC
A=FC/APC
S=SC/PC
G=SC/APC
R=Ferrule only

Collimator _____

None = 0
Or M, N, P, Q

Example: FMXL-0785-040-SF0A, FiberMAX785™ laser module with 785nm Laser diode, 40 mW power output, single mode fiber in 3mm jacketing, FC/PC connector, no collimated beam output optics, and A type pin-out.

Mechanical Outline

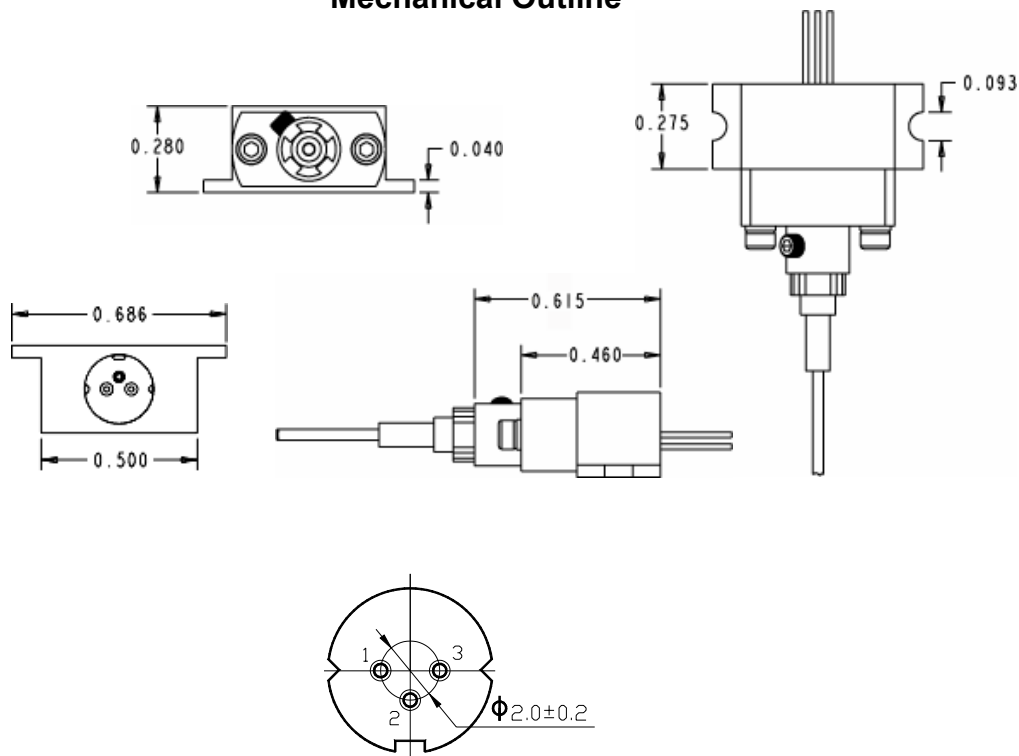

A Pin-out.
Case is cathode.

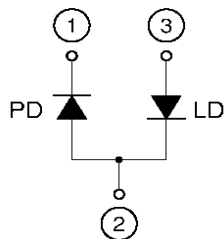

B Pin-out.
Case is anode.

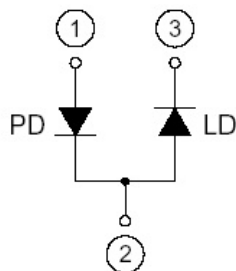

Handling Care and Precautions for Use of FiberMax™ Modules

1. Absolute Maximum Ratings

Do not exceed, *even momentarily*, the maximum ratings (see page 1, table). When a FiberMax module is driven in excess of its maximum ratings, it can cause at minimum a considerable reduction in reliability, and potentially instantaneous failure.

- a. FiberMax modules may be damaged by surge currents generated at power on-off operation. Check on the transient characteristics of the power supply to make sure that such surges do not exceed the maximum ratings.
- b. The maximum ratings are specified for a case temperature of 25°C. Designs should be made to work well within this temperature range. As the case temperature goes up, power dissipation as well as maximum light output power is reduced.

2. Soldering Conditions

Maximum solder-tip temperature is 260°C and soldering time must be within 3.0 seconds. A minimum solder clearance of 1.6mm should be maintained from the root of the lead.

3. Prevention of Breakdown due to Static Electricity

FiberMax modules may be adversely affected by static electricity and surge currents and, consequently, cause breakdown of the module and reduction of reliability unless the following precautions are taken:

- a. Power supplies, installation and measuring equipment should be grounded. A noise filter or noise-cut transformer should be provided on any power supply inputs.
- b. Anyone working with a FiberMax module should be grounded through high resistance (500 K Ohm - 1M Ohm) by means of a ground strap and wrist band (for example).
- c. Soldering irons should be grounded to protect laser modules from voltage leaks.
- d. During operation of the FiberMax module, working clothes, hats, and shoes should be static-protected. Cotton-based clothing is preferred.
- e. Any container for carriage and storage should be static-protected.
- f. Avoid using laser modules in an environment where high frequency surge currents may be generated by an inductive electric field (such as a fluorescent lamp). These fields can also cause breakdown or deterioration of the laser module.

4. Package Handling

- a. The laser module package should not be cut off, reworked, or deformed. Care should be taken when handling the fiber to avoid kinking it.
- b. Do not touch the ferrule end. Any scratch or contamination may result in reduction of optical characteristics.
- c. Remove small contaminants on the ferrule surface carefully using a soft cotton tip stick with a small amount of methyl alcohol.

5. Safety

The output light from laser modules is harmful to a human body even if it is invisible. Avoid looking at the output light of a FiberMax module directly, or even indirectly through a lens during operation. Observance of operation should be through an infrared TV camera or related equipment. Refer to IEC 825-1 and 21 CFR 1040.10-1040.11 as a radiation safety standard for laser products.

